

**PRESSES  
PLIEUSES  
HYDRAULIQUES** **PPS**

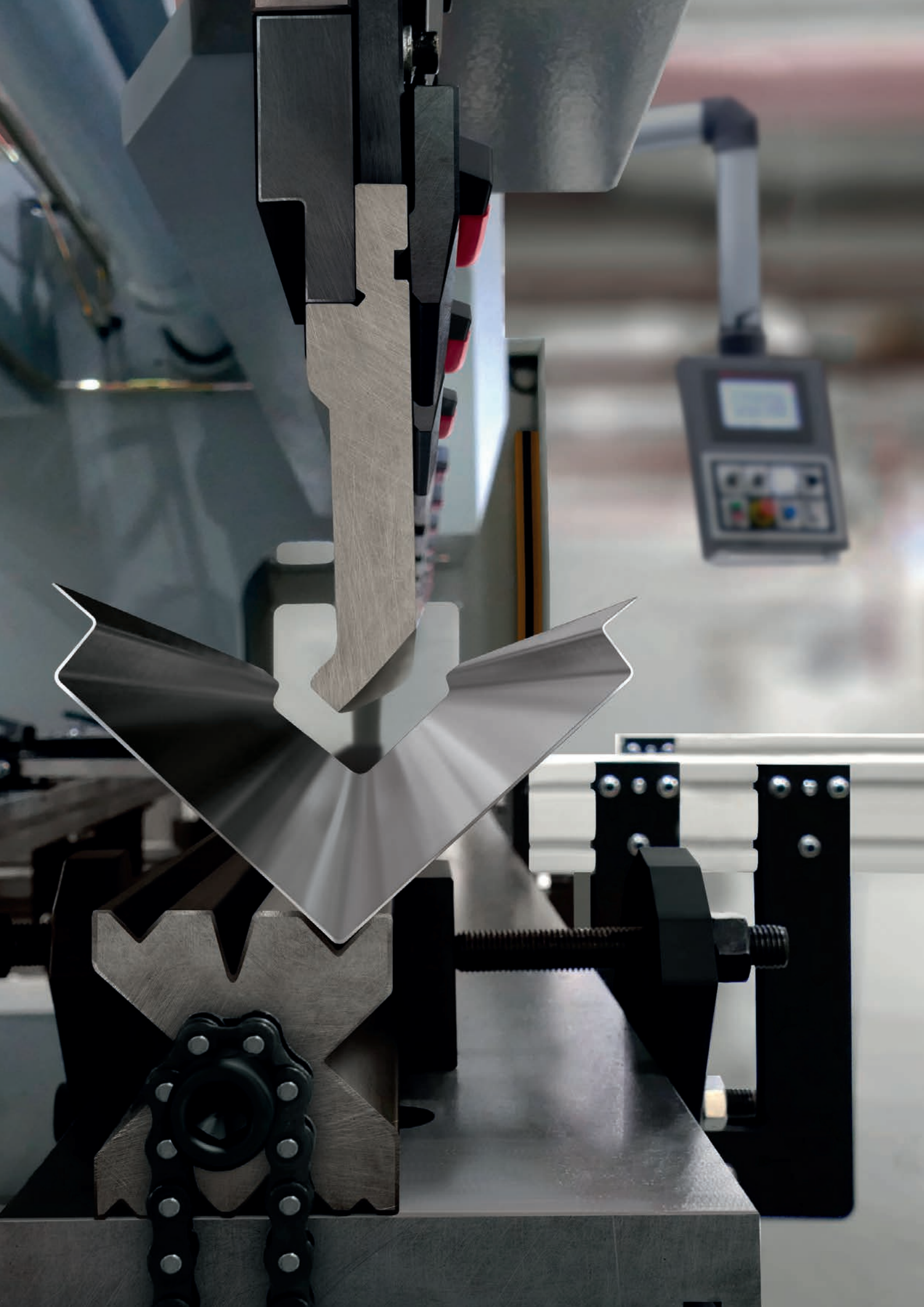





# SOMMAIRE

## Presses plieuses hydrauliques PPS

■ Caractéristiques et Équipements .....	6-7
■ Commande numérique .....	8
■ Équipements complémentaires .....	9
■ Données techniques .....	10
■ Abaque pour pliage en l'air .....	11
■ Blocs Multi-vé .....	12

## Outillage complémentaire

■ Poinçons rectifiés .....	13-23
■ Matrices rectifiées .....	24-33
■ Outils à écraser .....	34

*Toutes les dimensions exprimées dans ce fascicule sont en millimètres*



**PRESSES  
PLIEUSES  
HYDRAULIQUES** **PPS**



## ■ Efficacité & fiabilité

De conception robuste, les presses plieuses de la gamme **PPS** sont parfaitement adaptées au pliage de la tôle dans les ateliers de métallerie. Précises et fiables, elles sont équipées d'une barre anti-torsion largement dimensionnée permettant d'assurer un bon parallélisme du coulisseau mobile lors de la descente en pression.

Conformité



## ■ Caractéristiques & Équipements

- Barre anti-torsion largement dimensionnée assurant un bon parallélisme du coulisseau mobile lors de la descente en pression
- Table de travail rectifiée démontable et réajustable pour une grande précision et une bonne longévité
- Bloc hydraulique avec double sécurité, pression réglable
- Support de tôle avant 500 mm, réglable pour un bon confort de travail **1**
- Butée arrière montée sur glissière pour les pièces de petite largeur, réglable en hauteur **2**, profondeur ajustable par vis micrométrique **3** garantissant une grande précision, doigts de butée escamotables **4**
- Commande numérique tactile **5** avec gestion 2 axes X et Y, possibilité de création de programmes (détail Pg 8) (plusieurs milliers, 80 plis par programme), sauvegarde et mise à jour par clé USB **6**
- Dispositif de retournement rapide et sans effort des vé **7**
- Bloc multivé différent selon les modèles (détail Pg 12)
- Poinçons 86° rayon 0,6 mm, longueurs 415 mm, 835 mm ou 805 mm (fractionné avec bigorne) suivant modèle
- Barrières immatérielles de sécurité avant : classe 4 **8**
- Commande par pédale, bouton d'arrêt d'urgence **9**
- Alimentation 400 V tri + neutre

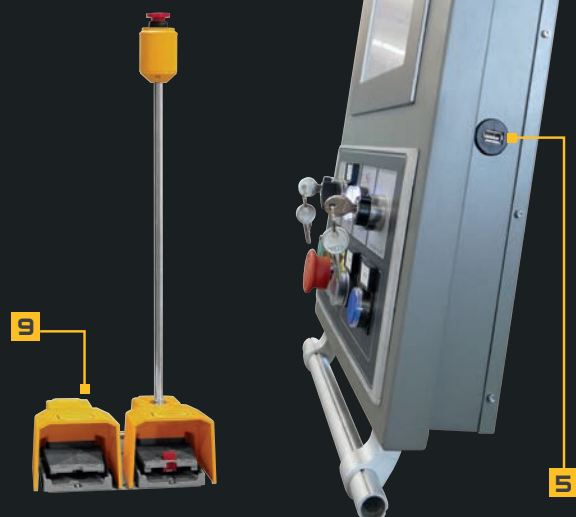
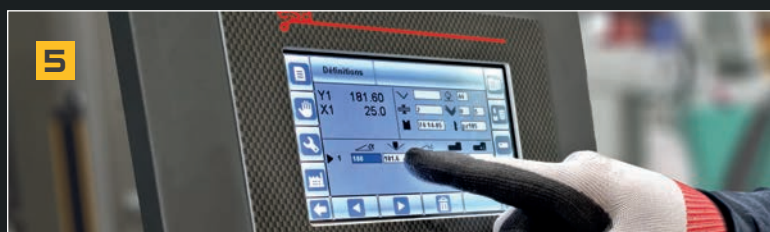



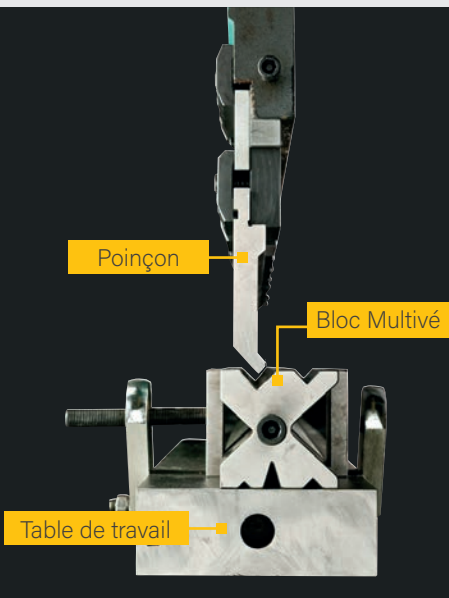

## ■ Commande numérique

### CN 2 AXES ESA-625

Cette commande numérique offre une configuration flexible et conviviale complète, comprenant la commande des axes pour le coulisseau et la butée arrière.

- Écran tactile de 7"
- Opérations simples et intuitives
- Stockage de programmes
- Commande de butée arrière avec fonction recul
- Correction d'angle possible suivant la matière
- Compteur de pièces
- Programmation des outils
- Fonction de travail manuelle, semi-automatique et automatique



### ÉCRAN D'ACCUEIL

Vision d'ensemble sur la tâche en cours.  
Réalisation d'un seul pli avec données saisies en amont.

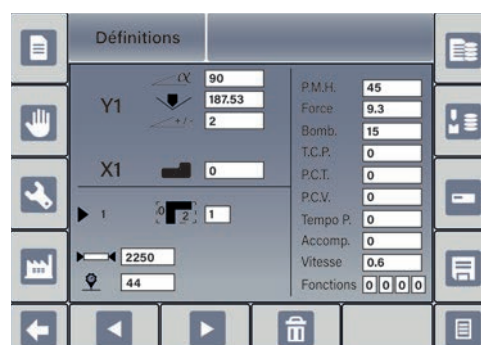

### PLUS D'INFORMATIONS

Second écran d'accueil avec caractéristiques plus précises.

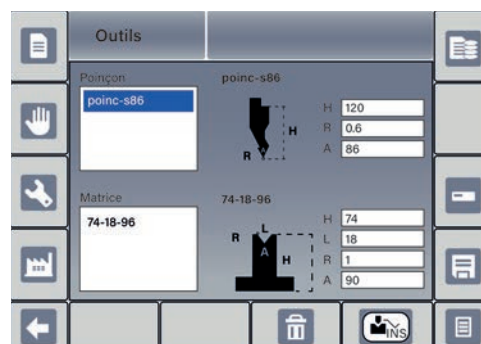

### PROGRAMMATION D'OUTILS

Ajout de poinçons et de matrices.  
Enregistrement des caractéristiques propres aux outils ajoutés.

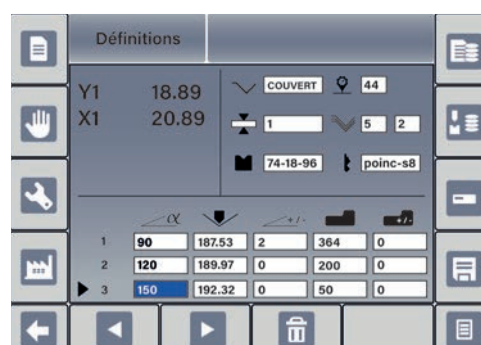

### RÉALISATION DE PLUSIEURS P LIS

Pliage des plis programmés dans l'ordre indiqué à l'écran.



# Équipements complémentaires

## TABLES

Tables adaptables	Longueurs	Référence
Pour matrices base 60 mm avec vé autocentrés	1010 mm	PPS-T1100B60
	2100 mm	PPS-T2100B60
	3100 mm	PPS-T3100B60
	4100 mm	PPS-T4100B60

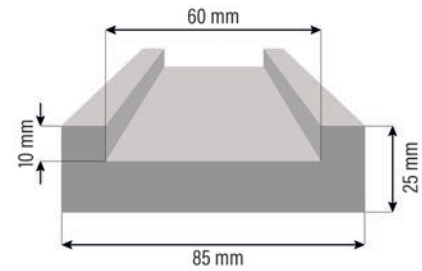

Dispositifs de bombage hydraulique à réglage de pression manuelle  <b>(Équipement à prévoir à la commande de la machine)</b>  Pour plus d'informations, nous consulter.	1010 mm	PPS-BHRM1
	2100 mm	PPS-BHRM2
	3100 mm	PPS-BHRM3
	4100 mm	PPS-BHRM4

Possibilité de gestion automatique  
du bombage de table par la commande numérique  
Nous consulter

Butées arrières	Référence
Réglage manuel de hauteur à l'arrière de la machine	PPS-BRM
Réglage électrique de hauteur par commande à l'avant de la machine	PPS-BRE
Bras supplémentaire de support de tôle avant longueur 500 mm	PPS-ST-SUP
Autres besoins, nous consulter	

Brides pour le serrage rapide des outils	Référence
Serrage manuel	PPS-SR



## DIVERS



## Données techniques

RÉFÉRENCE MACHINE	PPS1030	PPS2050	PPS3080	PPS3120	PPS3160	PPS3200	PPS3250	PPS3300	PPS3400	PPS4120	PPS4160	PPS4200	PPS4250	PPS4300	PPS4400	PPS4500	PPS6160	PPS6200	PPS6250	PPS6350	PPS6450	PPS6550
Longueur utile de pliage (mm)	1100	2200	3200				3200			4100			4100			6100			6100			
Force Tonne machine	30	50	80	120	160	200	250	300	400	120	160	200	250	300	400	500	160	200	250	350	450	550
Passage entre montants (mm)	800	1800	2650				2650			3100			3100			5100			5100			
Profondeur du col de cygne (mm)	250		320				350			320			350			320			350			
Course du coulisseau (mm)	120	120	120	150	150	200	200	250	250	150	150	200	200	250	250	250	200	200	200	250	250	300
Ouverture maxi (mm)	340	340	370	370	410	470	470	570	570	370	410	470	470	570	570	570	450	540	540	550	630	630
Hauteur de table (mm)	800	800	900	900	900	1050	1050	1150	1200	900	900	1050	1050	1150	1150	1000 /700	1000	1100	1500	1000 /700	1000 /900	1000 /1000
Course de butée arrière (mm)	5-500	5-600	5-600				5-800			5-600			5-800			5-600	5-800					
Doigts de butée	2	2	4	4	4	4	4	4	4	4	4	4	4	4	4	4	4	4	4	4	4	4
Puissance moteur (kW)	4	5.5	7.5	11	11	15	18.5	25	30	11	11	15	18.5	25	30	30	11	15	18.5	30	30	30
Vitesse rapide (mm/s)	80	80	80	80	80	80	80	80	80	80	80	80	80	80	80	80	80	80	80	80	80	80
Vitesse de travail (mm/s)	10	10	10	10	9	9	9	9	9	10	9	9	9	9	9	9	9	9	9	9	9	9
Longueur (mm)	1700	2700	3700				3700			4600			4600			6600			6600			
Largeur (mm)	1700	1500	1550	1650	1700	1850	1850	2050	2150	1700	1700	1850	1850	2050	2150	2300	1850	1950	1950	2150	2300	2350
Hauteur (mm)	2100	2150	2210	2350	2450	2450	2800	3400	3450	2450	2500	2800	2850	3400	3450	3550	2950	3180	3250	3600	3650	3900
Poids (kg)	1980	4000	5100	7200	8650	11200	12500	19500	21000	9200	10500	13500	14650	21250	24300	31000	15500	19520	22340	29200	39520	48650

# ■ Abaque pour pliage en l'air

Force nécessaire en tonne/mètre pour de l'acier d'une résistance de 45daN/mm<sup>2</sup>

**V** : largeur du vé en mm  
(8 à 12 fois l'épaisseur de la tôle)

**R** : rayon en mm

**L** : longueur de pli mini en mm

**E** : épaisseur de tôle en mm

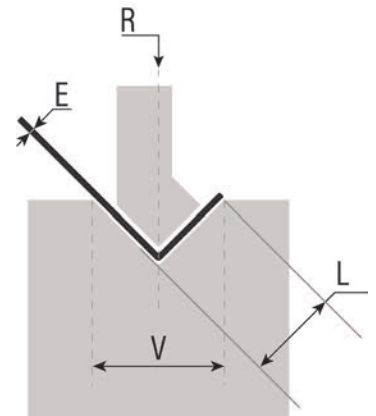

V	6	9,5	13	16	19	25	38	52	76	100	150	200	250
R	1	1,5	2	2,5	3	4	5,5	7,5	10	15	25	35	45
L	4,5	6	8	10	12	16	22	32	40	64	100	140	190
E	0,75	6	3										
1	11	8	5										
1,25	16	12	9	6									
1,5		18	15	10	7								
2				18	15	10							
3				43	36	25	16						
4					62	44	30	22					
5						65	50	34	24				
6							72	50	34	24			
8								88	62	46	30		
10									96	67	42	31	
12									130	100	62	46	32
14										133	85	70	52
16										180	110	90	75
19											130	100	90
22											170	130	100
25											220	165	130
30											220	210	170

## Calcul de correction de force suivant la dureté de la tôle

Pour plier une tôle de 3 mm d'une dureté de 45 daN/mm<sup>2</sup> sur 1 m, la force nécessaire sera de 25 T/m.

Si la tôle est d'une dureté de 70 daN/mm<sup>2</sup>, la force nécessaire sera de 38,75 T/m

**(25 T/m x 1,55 = 38,75 T/m)**

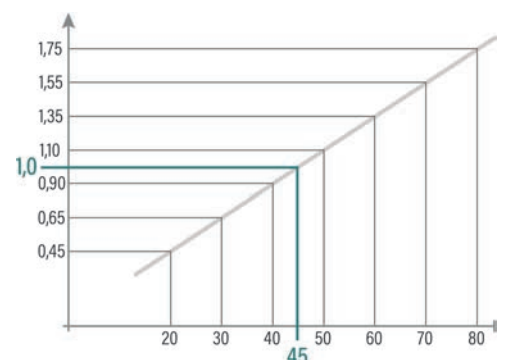



## ■ Blocs Multi-vé

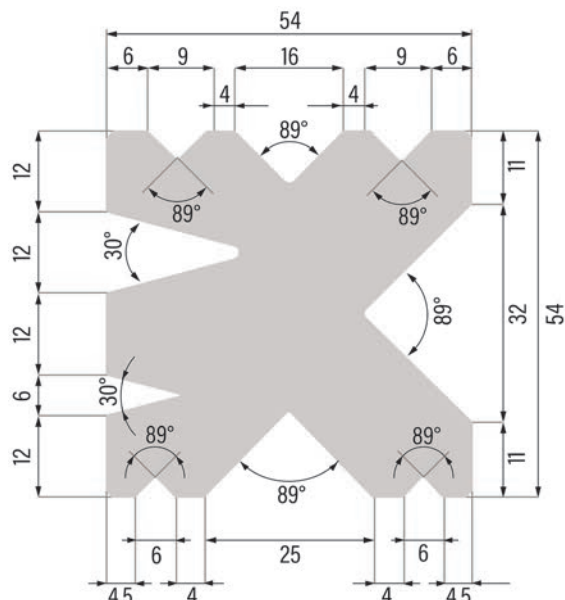
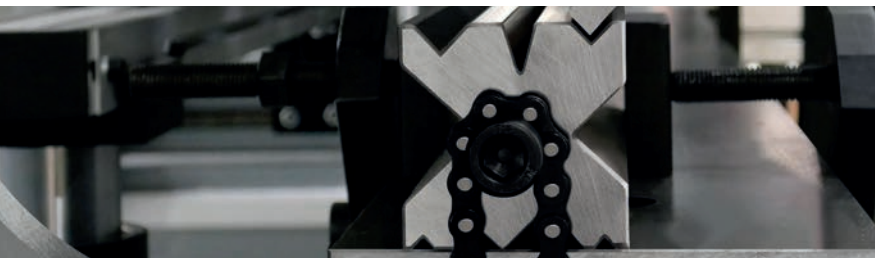

Bloc multi-vé livré avec presse plieuse de 30 et 50 tonnes

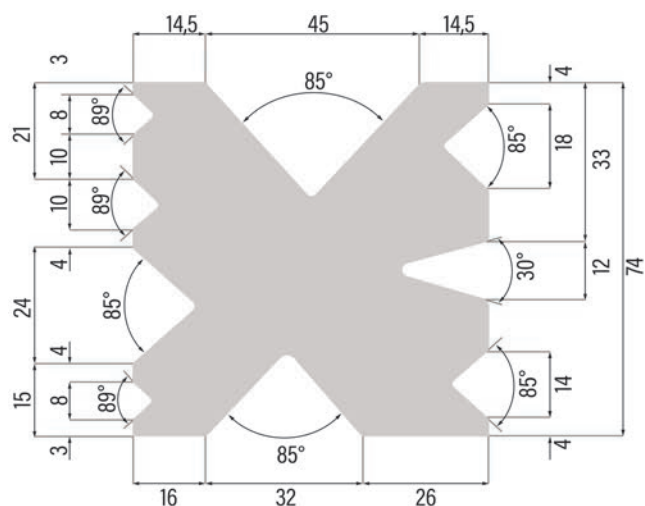

Bloc multi-vé livré avec presse plieuse de 80 tonnes

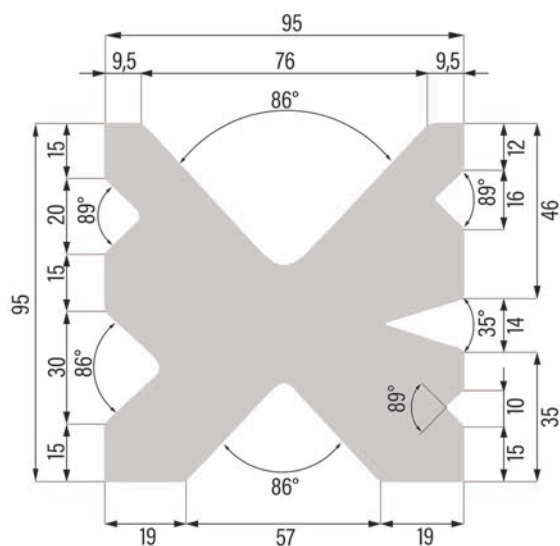

Bloc multi-vé livré avec presse plieuse de 120 tonnes

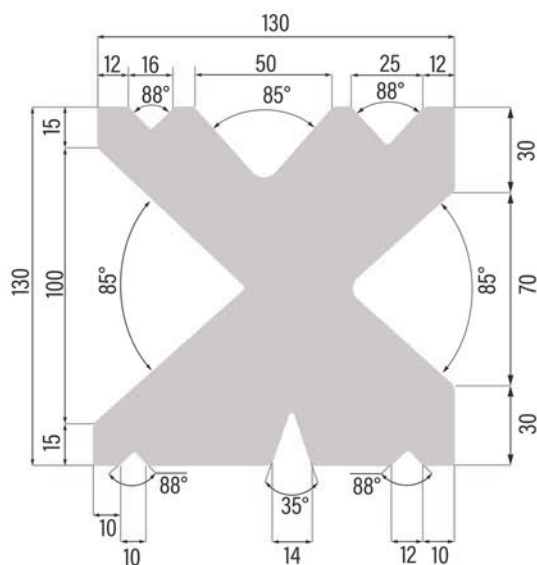

Bloc multi-vé livré avec presse plieuse de 160, 200 et 250 tonnes

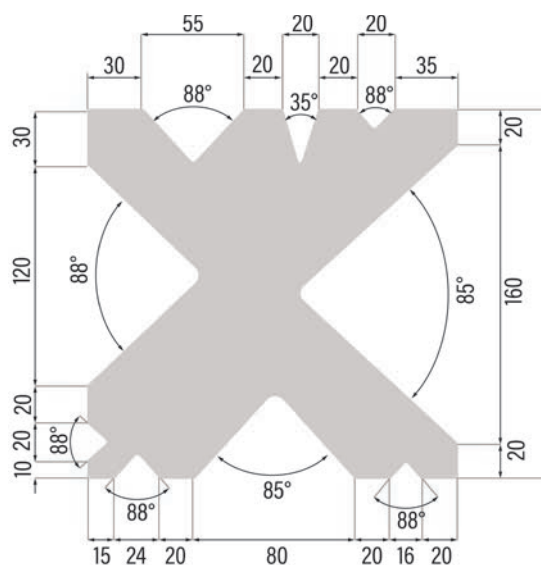

Bloc multi-vé livré avec presse plieuse de 300 tonnes et plus

# Poinçons - type AMADA PROMECAM

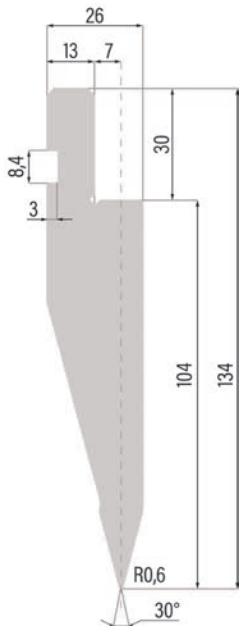

Réf. POIN-11.930

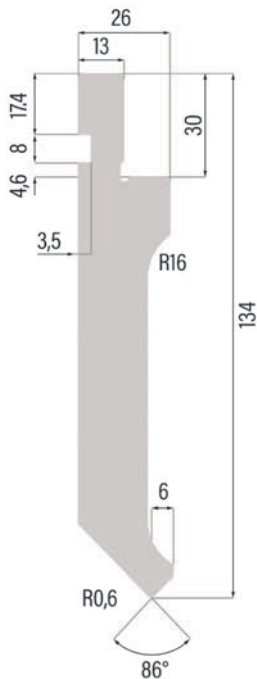
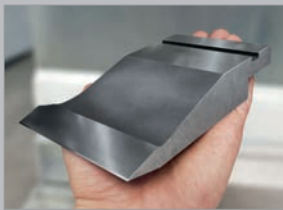

Poinçon standard  
Réf. POIN-S86-06

RÉF	<i>a</i>	R	H	T/m
RÉFÉRENCE	Angle	Rayon	Hauteur	Résistance tonne/mètre

Dimensions exprimées en millimètres

Poinçon 30° rayon 0.6 mm	Dimension	Référence
Court	415 mm	POIN11.930C
Long	835 mm	POIN11.930L

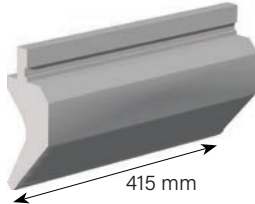
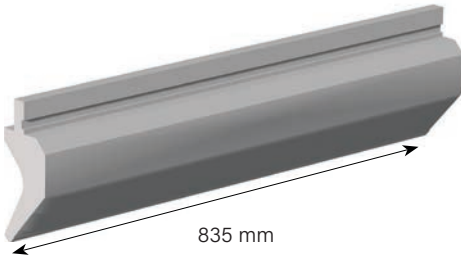
POINÇON COURT	POINÇON LONG
Référence + lettre C	Référence + lettre L
	

Poinçon fractionné avec bigornes (droite et gauche)		Angle	Référence
Segments (en mm)	100, 270, 10, 15, 20, 40, 50, 200, 100	86°	POIN-S86-0.6F
		30°	POIN11.930F

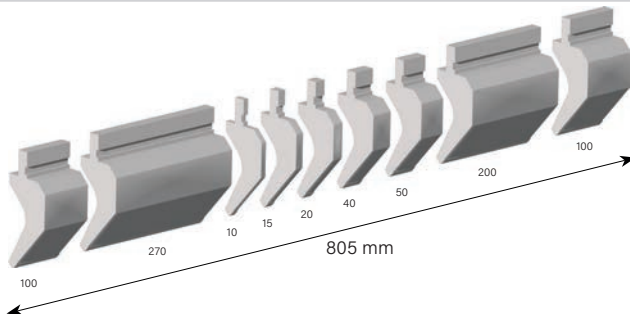
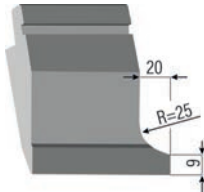

POINÇON FRACTIONNÉ	BIGORNE sur POINÇON FRACTIONNÉ
Référence + lettre F	
	



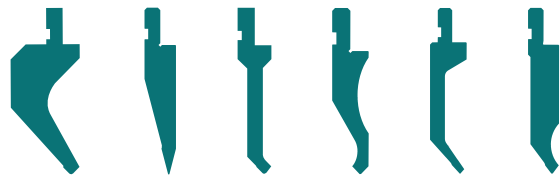

## ■ Poinçons 88°

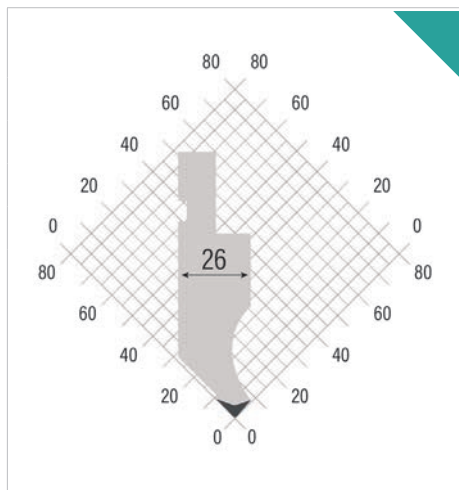

RÉF	$\alpha$	R	H	T/m
POIN10.110	88°	0,80	66,65	100
POIN10.120	88°	3,00	65,50	100
POIN10.650	88°	0,25	66,60	100

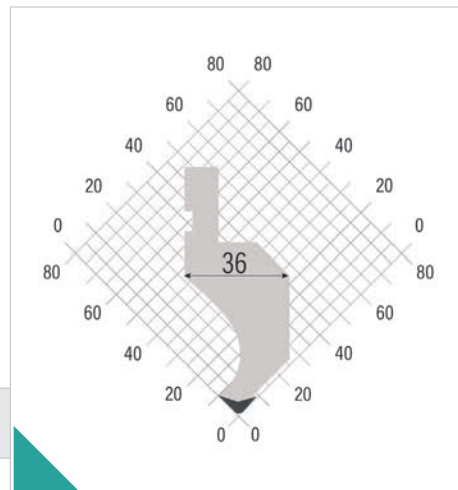

RÉF	$\alpha$	R	H	T/m
POIN10.810	88°	0,80	66,65	60

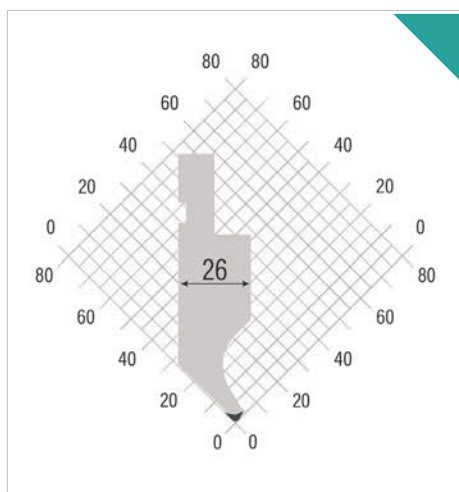

RÉF	$\alpha$	R	H	T/m
POIN10.490	88°	0,60	66,40	35
POIN12.640	88°	0,25	66,35	35

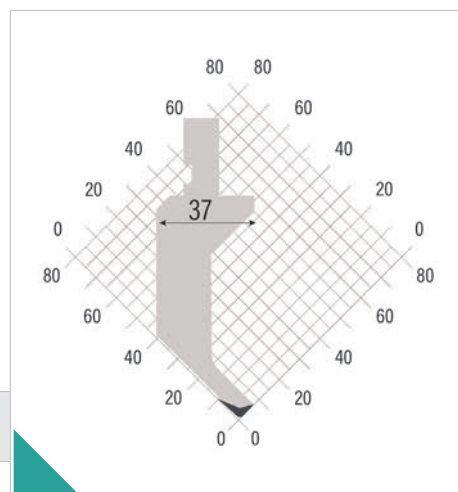

RÉF	$\alpha$	R	H	T/m
POIN10.200	88°	0,60	84,15	20

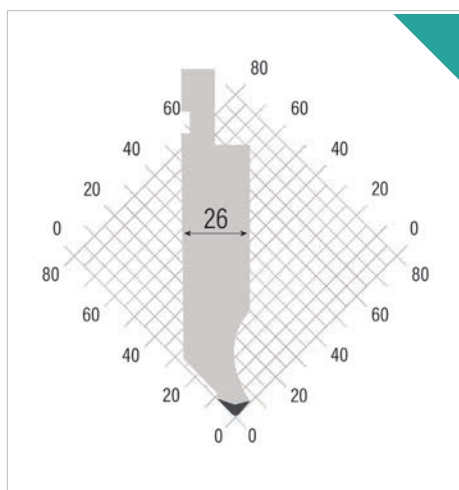

RÉF	$\alpha$	R	H	T/m
POIN10.630	88°	0,80	104,65	100

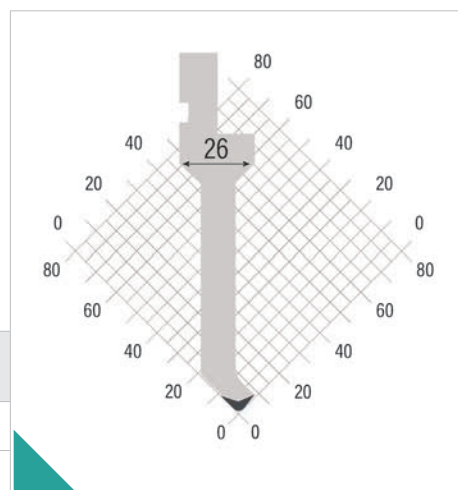

RÉF	$\alpha$	R	H	T/m
POIN10.290	88°	0,60	99,40	50
POIN12.620	88°	0,25	99,35	50



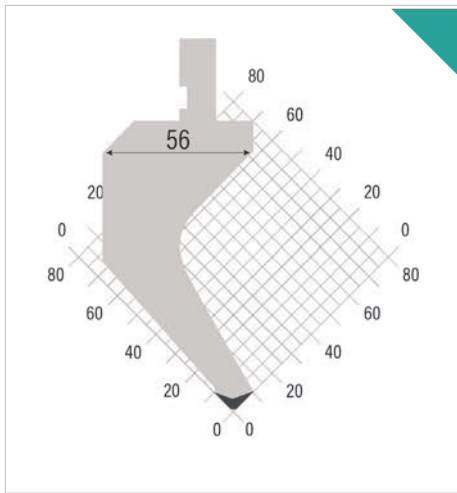

RÉF	$\alpha$	R	H	T/m
POIN10.170	88°	0.80	104.65	50
POIN10.180	88°	3.00	103.50	50
POIN12.680	88°	0.25	104.60	50

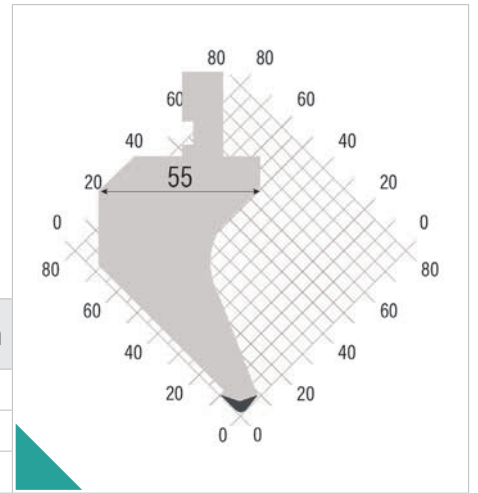

RÉF	$\alpha$	R	H	T/m
POIN10.140	88°	0.80	89.65	60
POIN10.150	88°	3.00	88.50	60
POIN12.660	88°	0.25	89.60	60

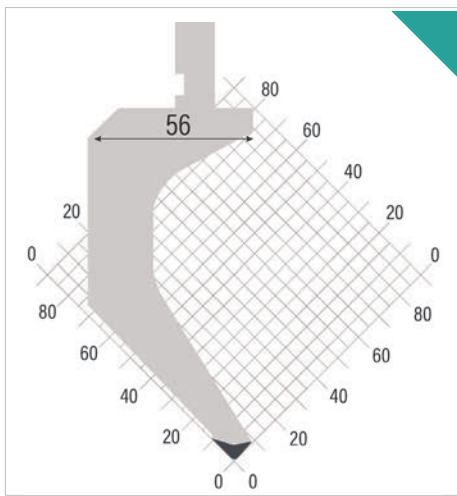

RÉF	$\alpha$	R	H	T/m
POIN10.610	88°	0.80	120.00	50
POIN10.620	88°	3.00	119.03	50

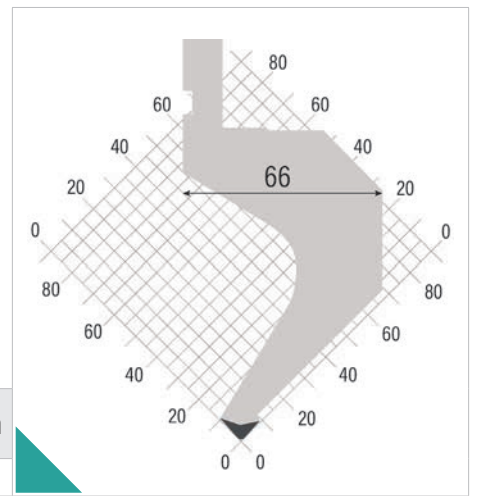

RÉF	$\alpha$	R	H	T/m
POIN10.820	88°	0.80	104.65	45

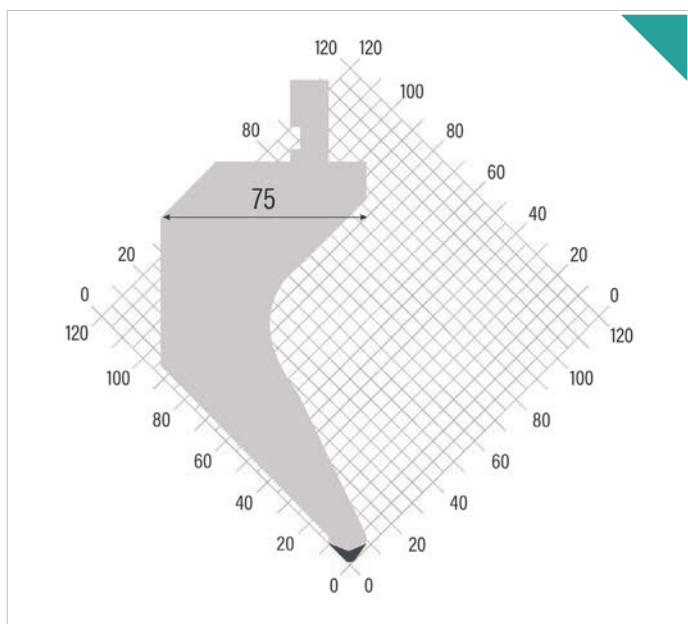

RÉF	$\alpha$	R	H	T/m
POIN10.300	88°	0.80	145.00	80

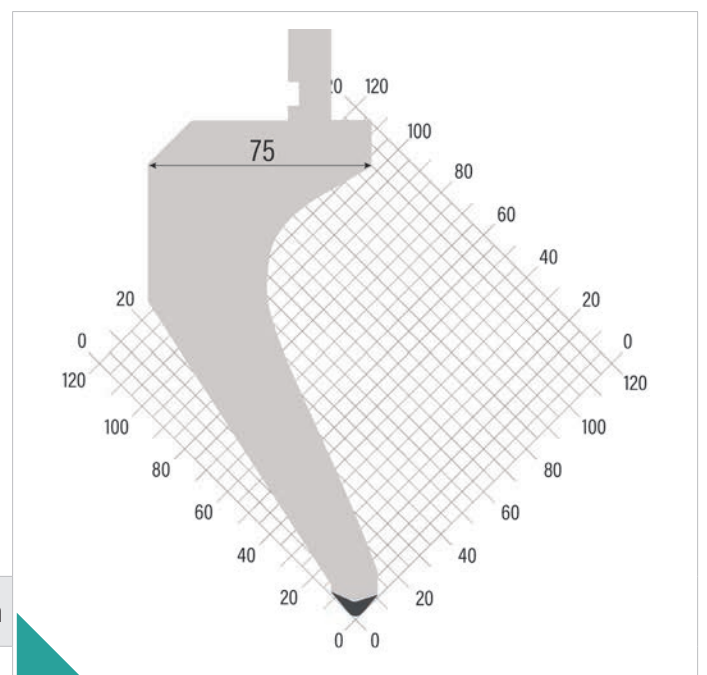

RÉF	$\alpha$	R	H	T/m
POIN10.310	88°	0.80	165.00	60

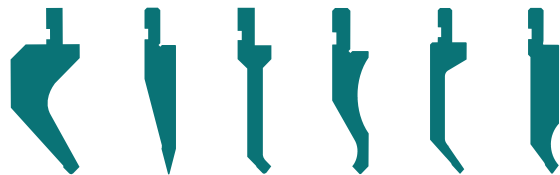

## ■ Poinçons 88° et 85°

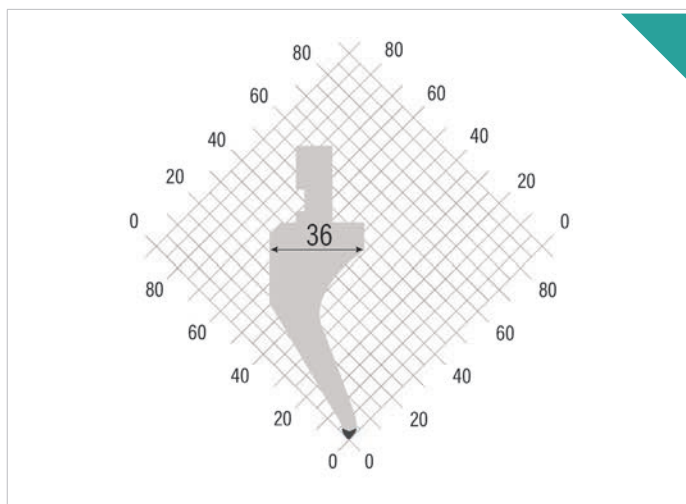

RÉF	$\alpha$	R	H	T/m
POIN13.010	88°	3.00	199.03	85

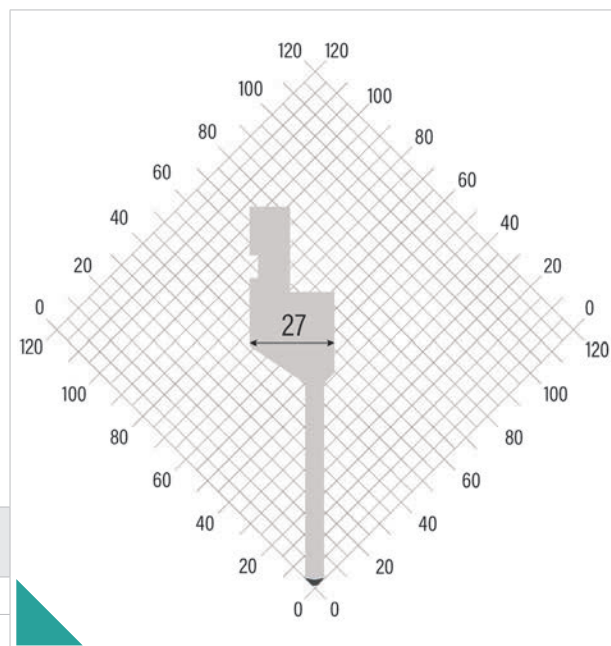

RÉF	$\alpha$	R	H	T/m
POIN10.840	88°	0.60	94.40	50
POIN12.700	88°	0.25	94.35	50

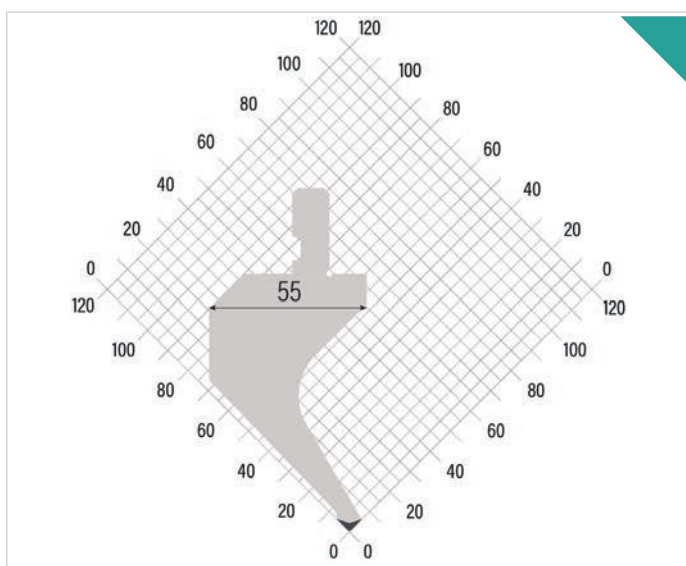

RÉF	$\alpha$	R	H	T/m
POIN11.750	88°	0.80	89.65	50

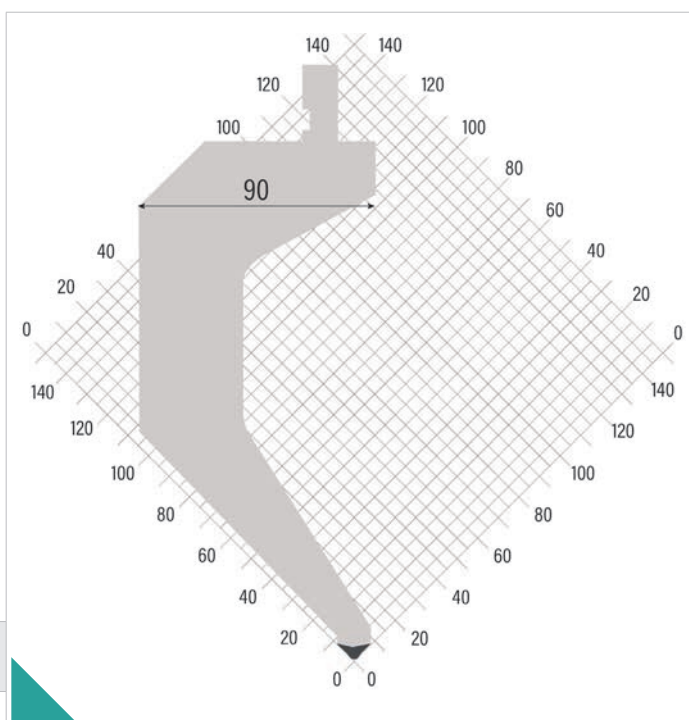

RÉF	$\alpha$	R	H	T/m
POIN12.910	88°	0.80	200.00	85

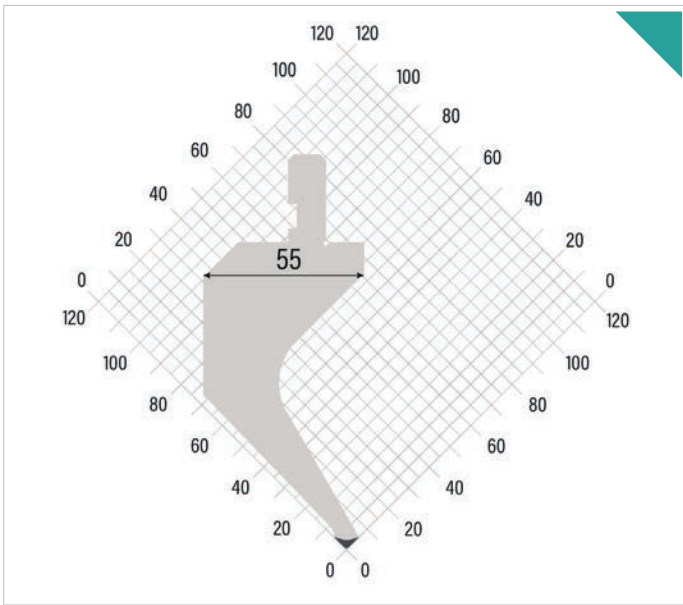

RÉF	$\alpha$	R	H	T/m
POIN1.730	88°	0.8	104.65	50

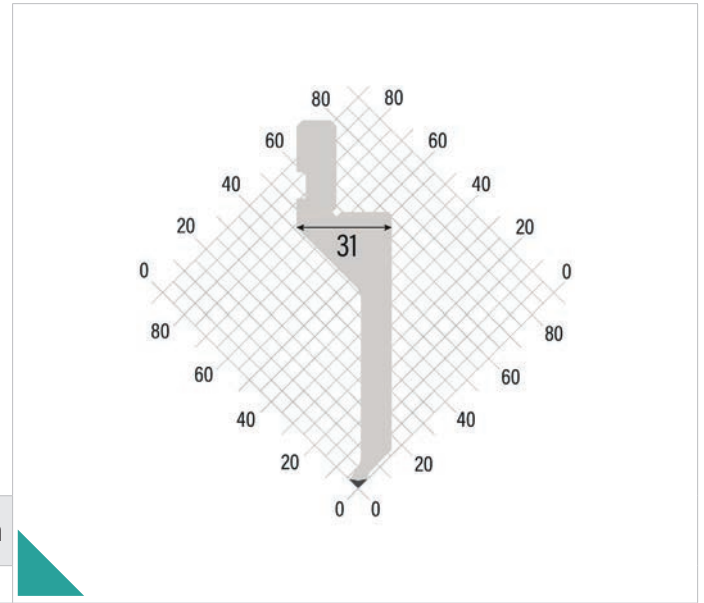

RÉF	$\alpha$	R	H	T/m
POIN12.900	88°	0.6	89.70	30

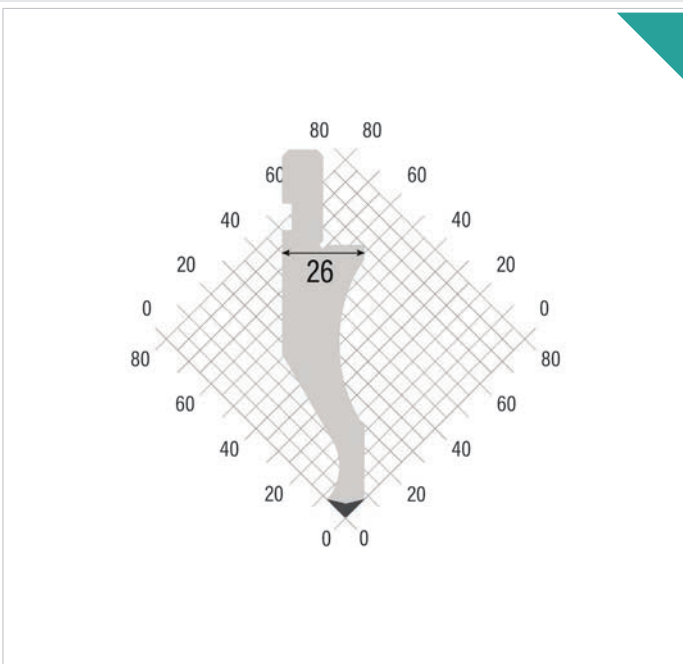

RÉF	$\alpha$	R	H	T/m
POIN10.220	88°	0.8	86	100
POIN10.230	88°	3	84.85	100

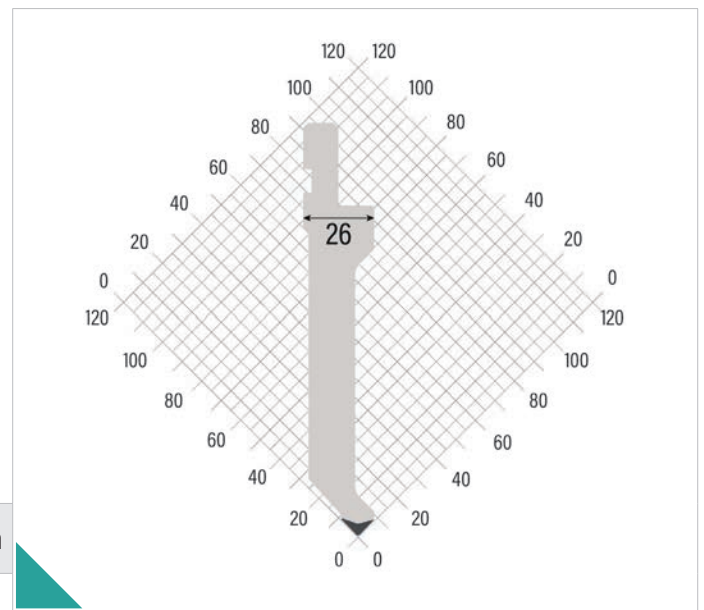

RÉF	$\alpha$	R	H	T/m
POIN13.090	85°	0.8	120	70

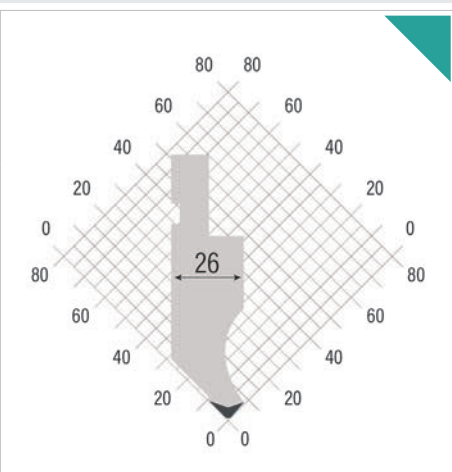

RÉF	$\alpha$	R	H	T/m
POIN11.770	85°	3,00	65,50	100
POIN12.600	85°	0,80	66,60	100

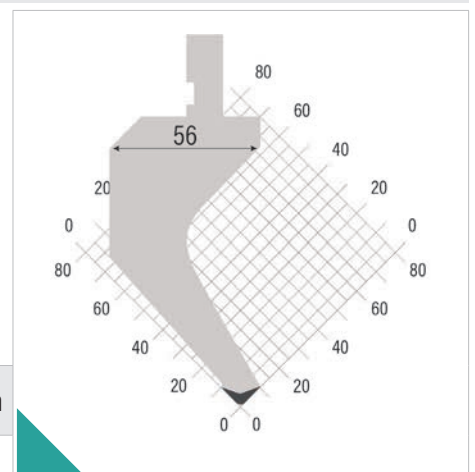

RÉF	$\alpha$	R	H	T/m
POIN11.720	85°	0.80	104.60	50



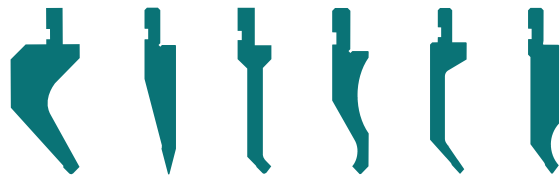

## ■ Poinçons 85°, 75° et 60°

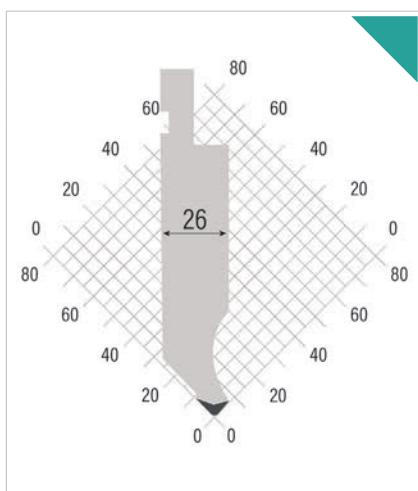

RÉF	$\alpha$	R	H	T/m
POIN12.810	85°	0.80	104.65	100

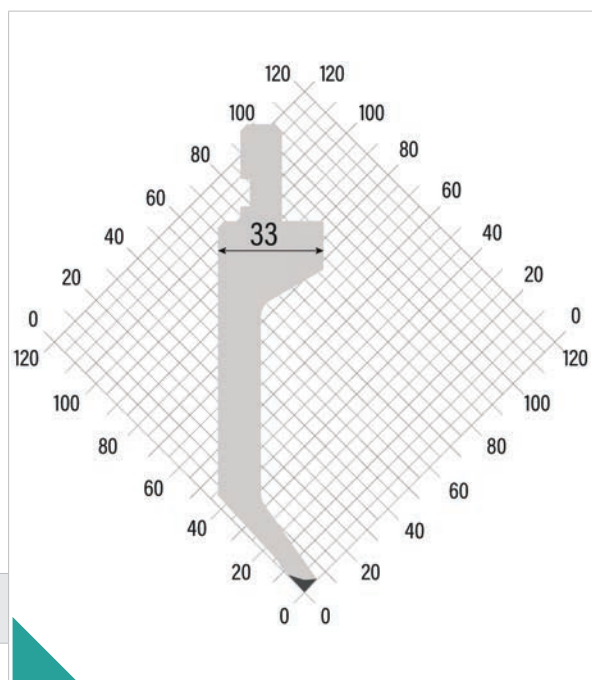

RÉF	$\alpha$	R	H	T/m
POIN13.120	85°	0.60	115.00	20

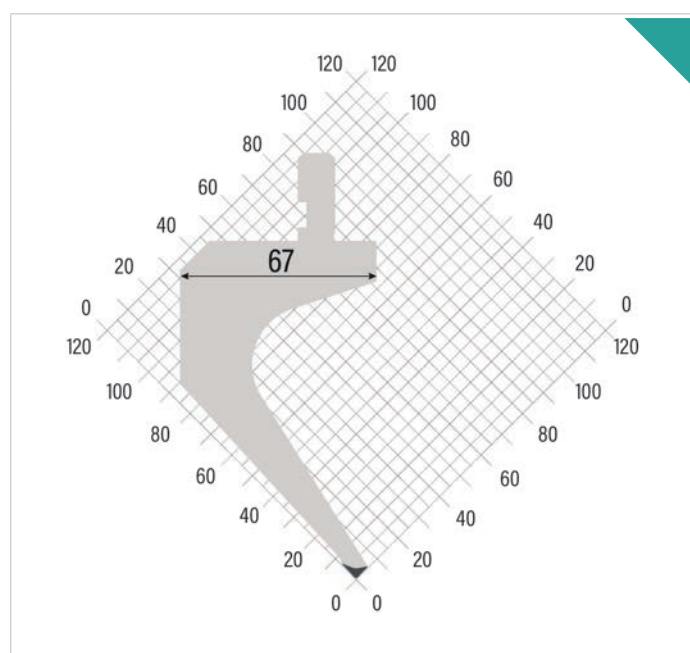

RÉF	$\alpha$	R	H	T/m
POIN13.100	85°	0.8	115.00	35

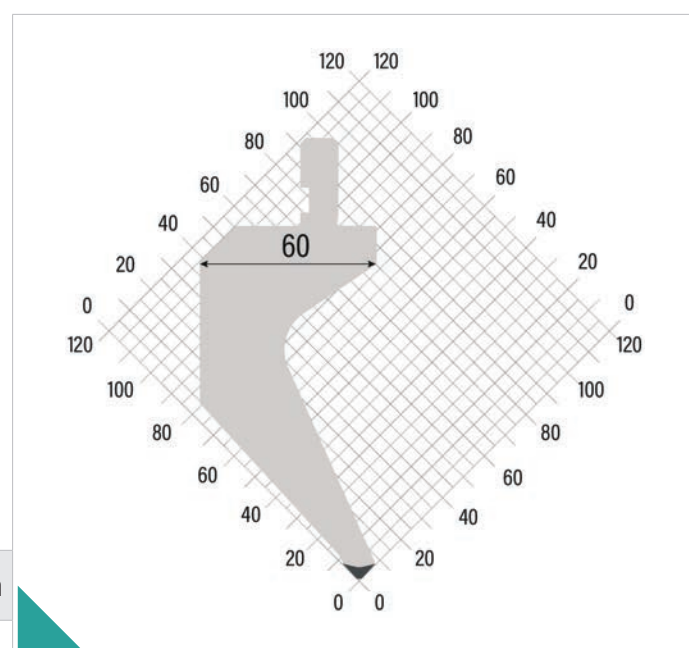

RÉF	$\alpha$	R	H	T/m
POIN13.220	85°	1.5	120.00	100

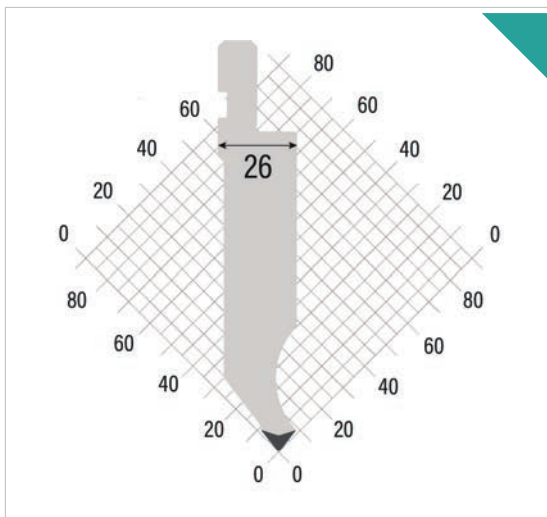

RÉF	$\alpha$	R	H	T/m
POIN13.380	75°	0.8	105	100

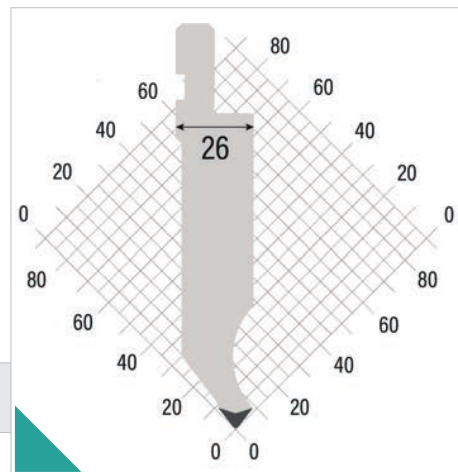

RÉF	$\alpha$	R	H	T/m
POIN13.390	75°	0.8	67.6	100

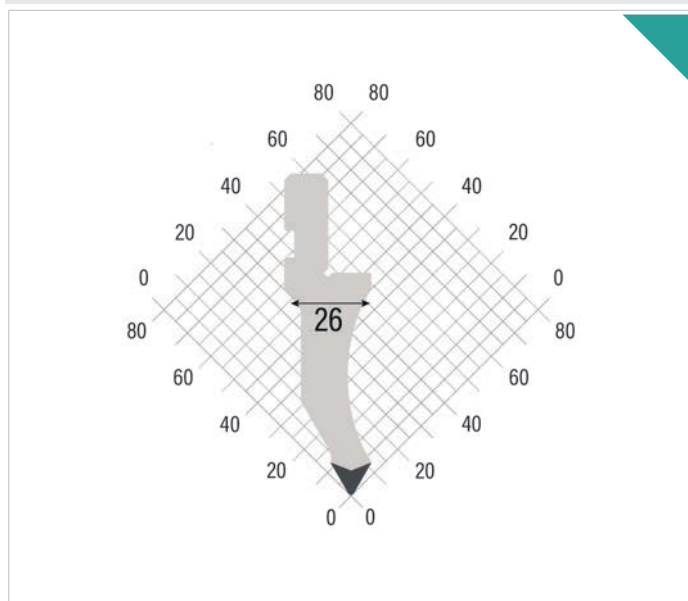

RÉF	$\alpha$	R	H	T/m
POIN10.260	60°	0.8	67.00	80
POIN10.270	60°	2	67.00	80

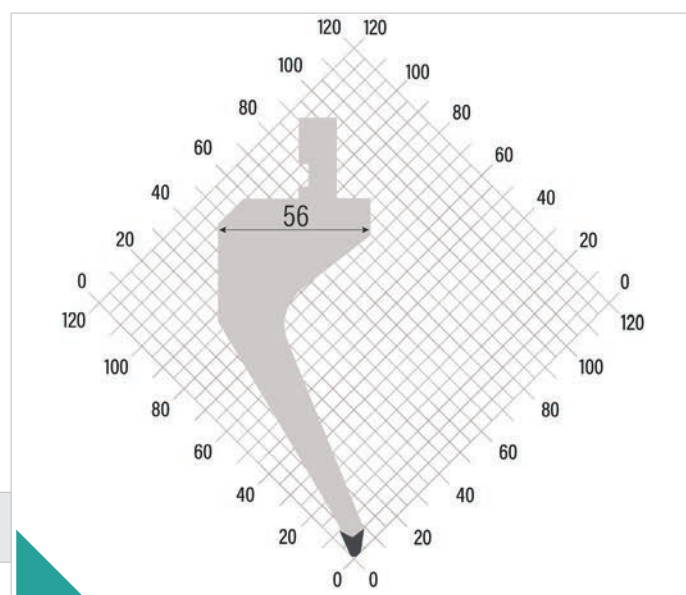

RÉF	$\alpha$	R	H	T/m
POIN11.630	60°	0.80	130.00	40

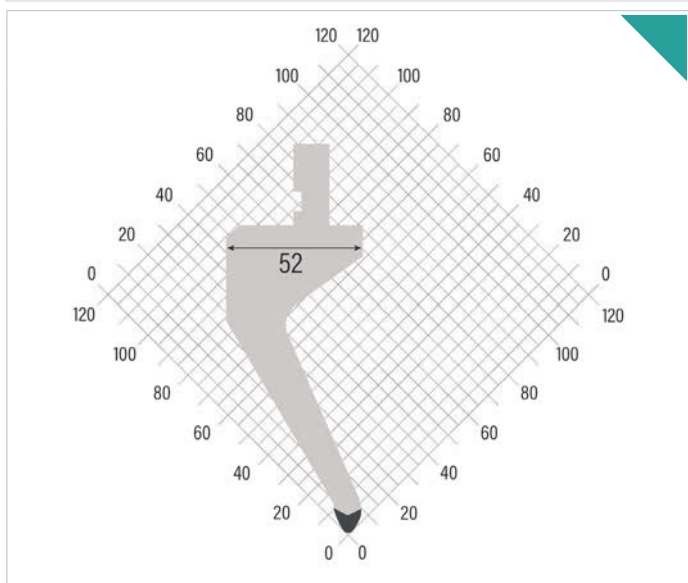

RÉF	$\alpha$	R	H	T/m
POIN12.720	60°	0.80	115.00	40

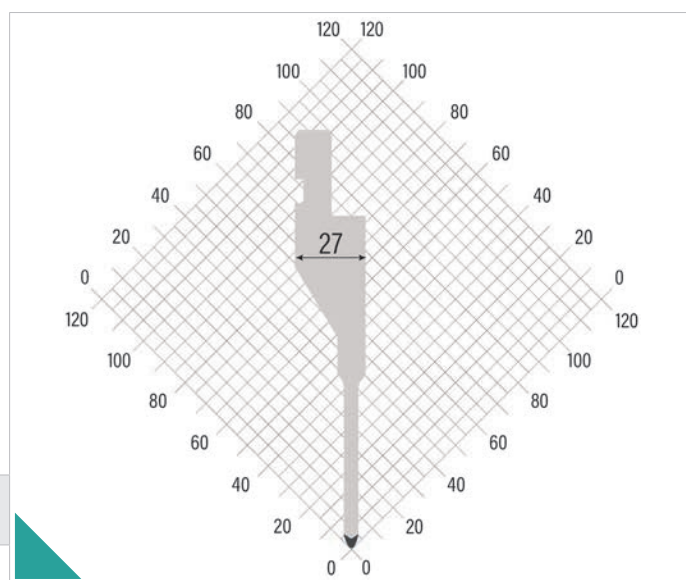

RÉF	$\alpha$	R	H	T/m
POIN12.710	60°	0.80	115.00	50

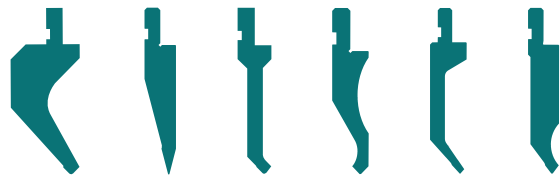

## ■ Poinçons 60° et 45°

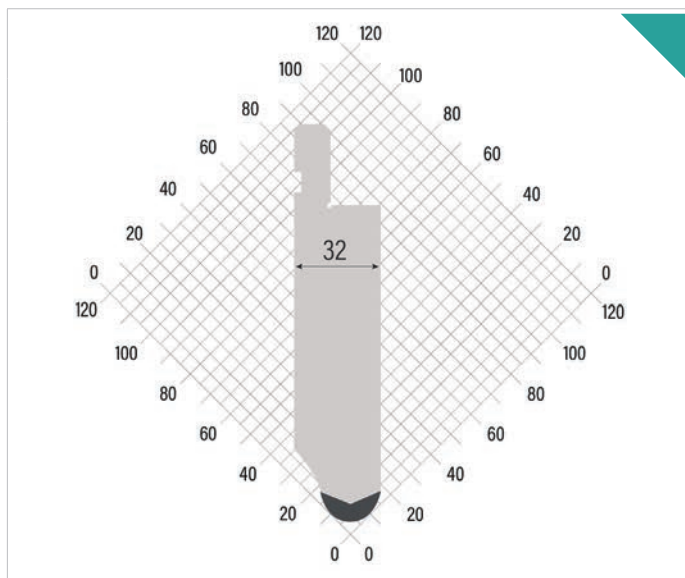

RÉF	$\alpha$	R	H	T/m
POIN12.830	60°	10.0	115.00	150

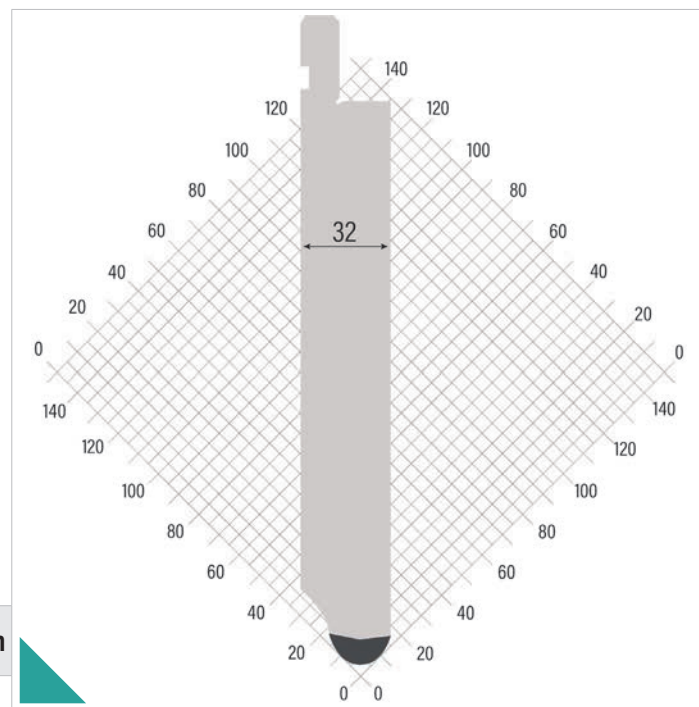

RÉF	$\alpha$	R	H	T/m
POIN12.930	60°	8.00	200.00	150

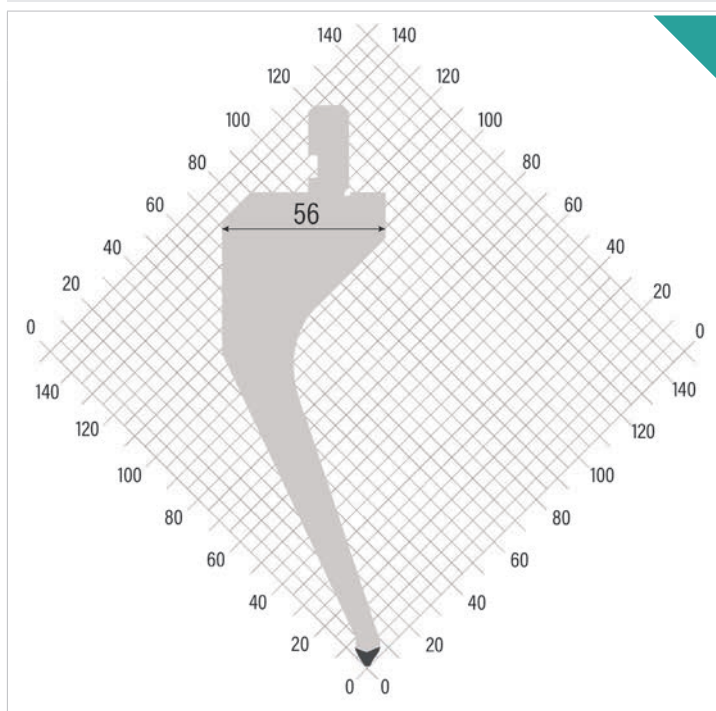

RÉF	$\alpha$	R	H	T/m
POIN1.900	60°	0.80	160.00	40

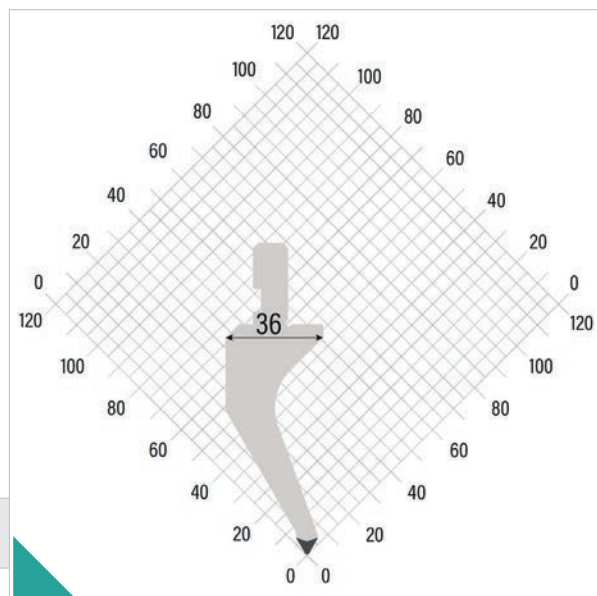

RÉF	$\alpha$	R	H	T/m
POIN1.620	60°	0.80	85.00	40



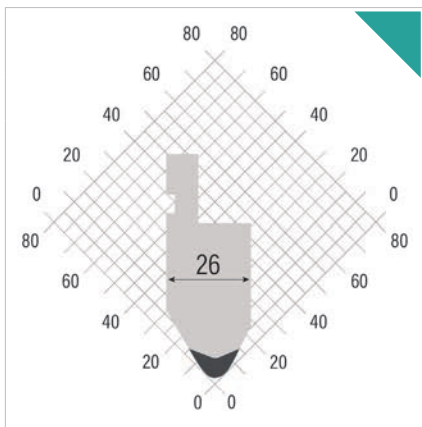

RÉF	$\alpha$	R	H	T/m
POIN10.320	60°	6.00	65.00	120

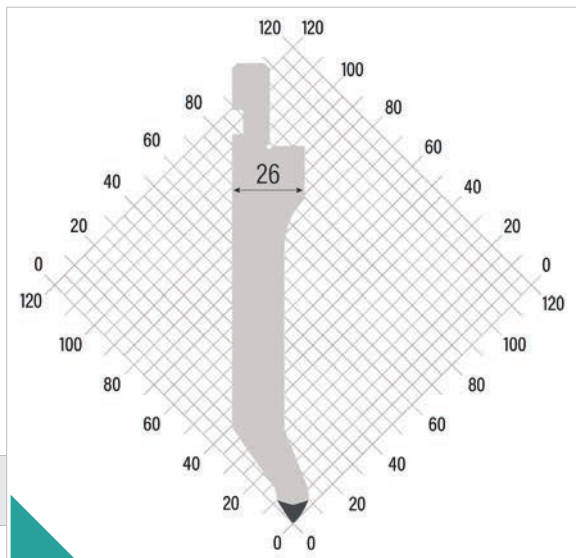

RÉF	$\alpha$	R	H	T/m
POIN12.840	60°	0.80	135.00	70

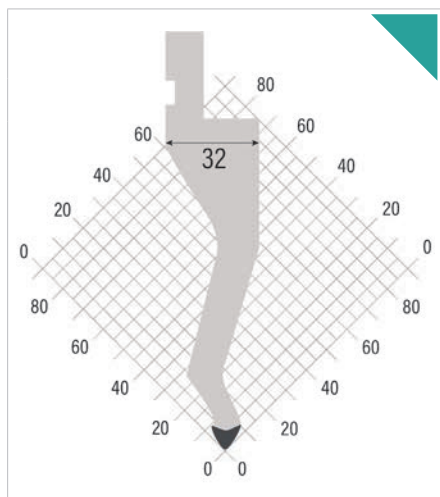

RÉF	$\alpha$	R	H	T/m
POIN11.910	60°	0.80	115.00	60

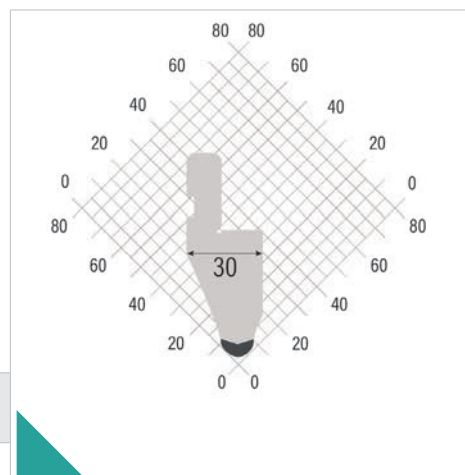

RÉF	$\alpha$	R	H	T/m
POIN10.540	45°	6.00	50.00	100

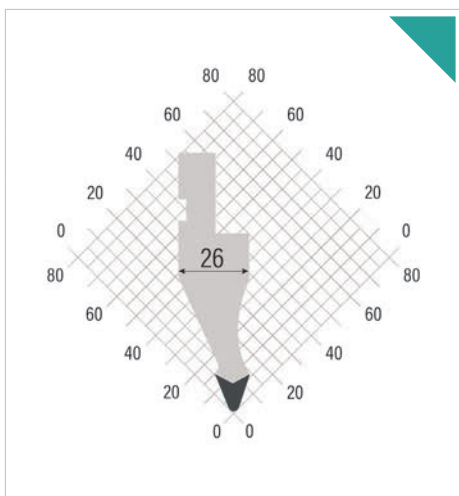

RÉF	$\alpha$	R	H	T/m
POIN10.240	45°	0.50	66.40	80
POIN10.250	45°	1.50	65.20	80

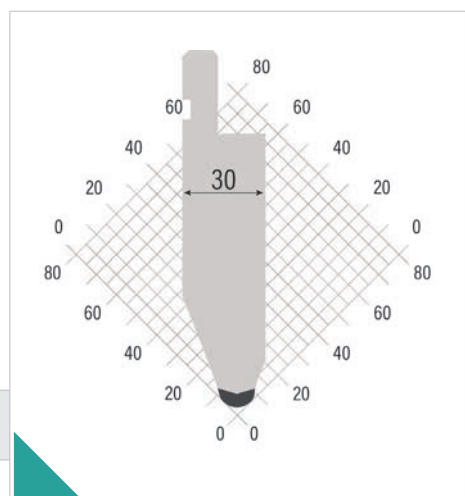

RÉF	$\alpha$	R	H	T/m
POIN10.530	45°	6.00	100.00	100

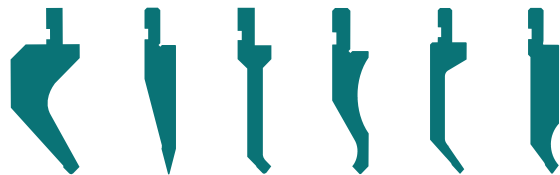

## ■ Poinçons 35°, 30° et 26°

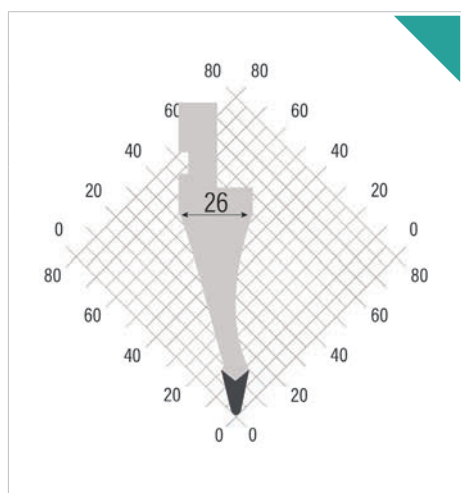

RÉF	$\alpha$	R	H	T/m
POIN10.350	35°	0.50	80.00	70
POIN10.470	35°	0.80	90.00	70
POIN12.820	35°	1.50	90.00	70

RÉF	$\alpha$	R	H	T/m
POIN10.340	35°	0.80	85.00	100

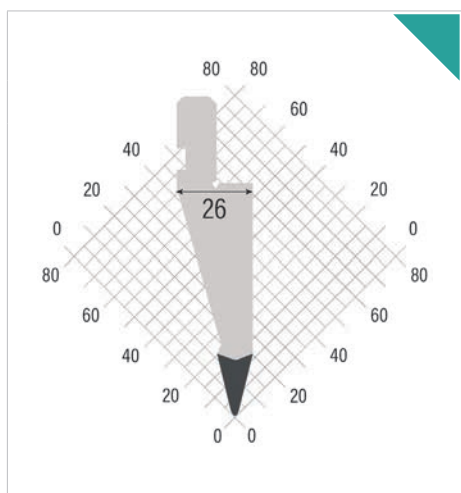
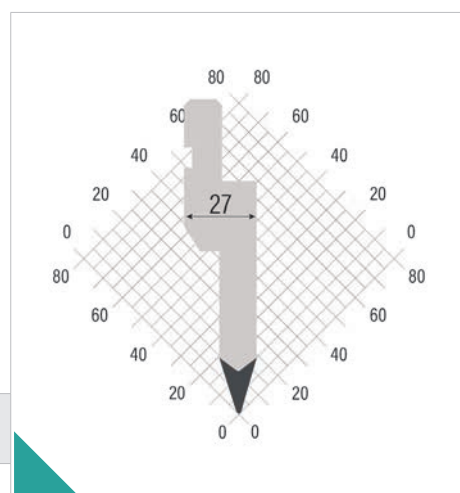

RÉF	$\alpha$	R	H	T/m
POIN10.560	30°	0.50	80.00	100

RÉF	$\alpha$	R	H	T/m
POIN11.930	30°	0.60	104.00	100

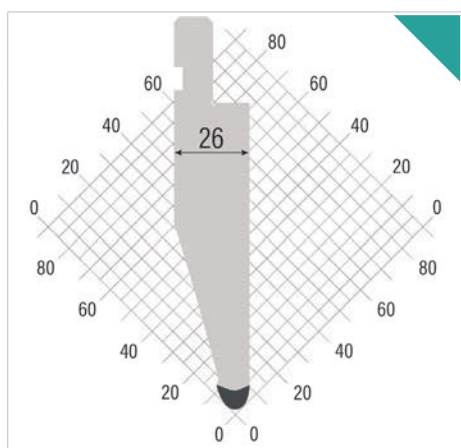
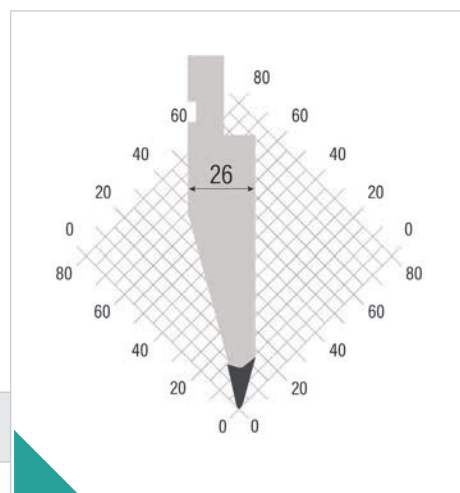

RÉF	$\alpha$	R	H	T/m
POIN11.940	30°	5.00	104.00	100

RÉF	$\alpha$	R	H	T/m
POIN12.890	30°	3.00	104.00	100

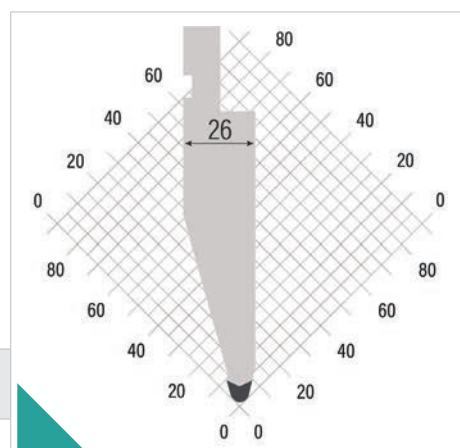

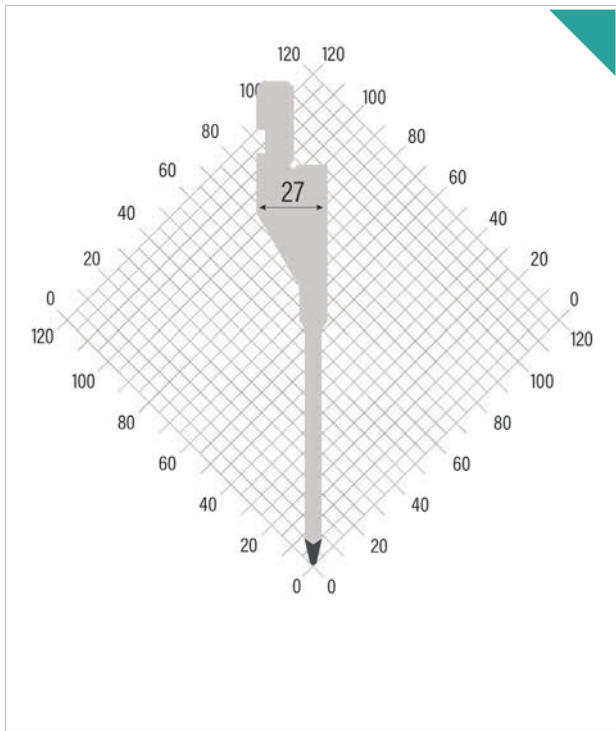

RÉF	$\alpha$	R	H	T/m
POIN10.860	30°	0.60	140.00	40

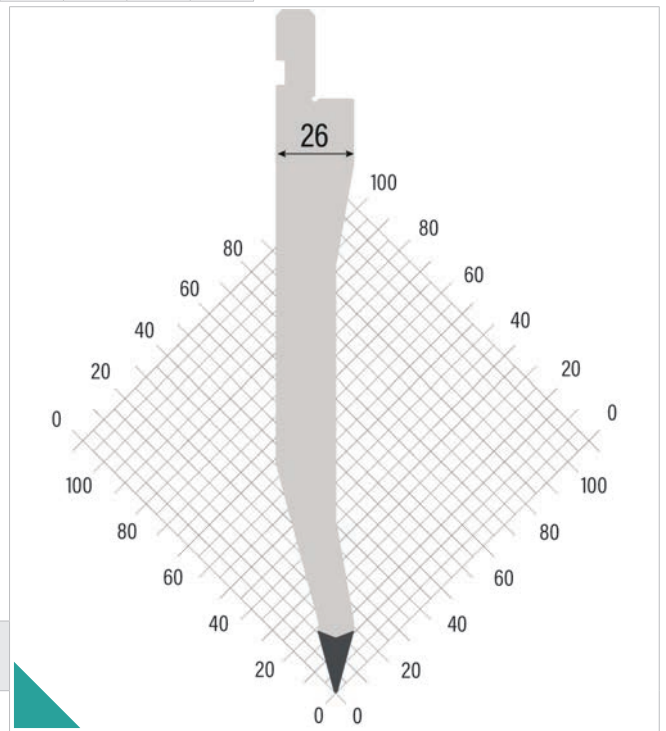

RÉF	$\alpha$	R	H	T/m
POIN12.920	30°	0.5	200	50

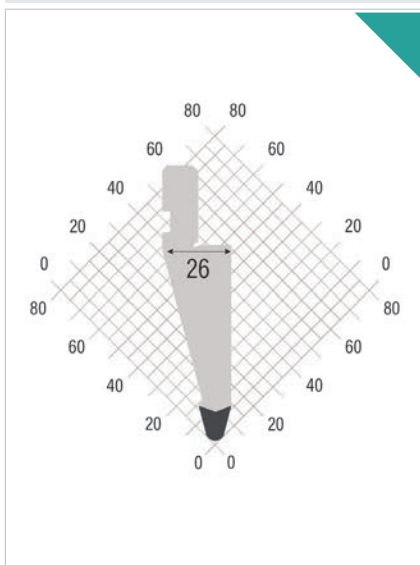

RÉF	$\alpha$	R	H	T/m
POIN10.570	30°	3.00	80.00	100

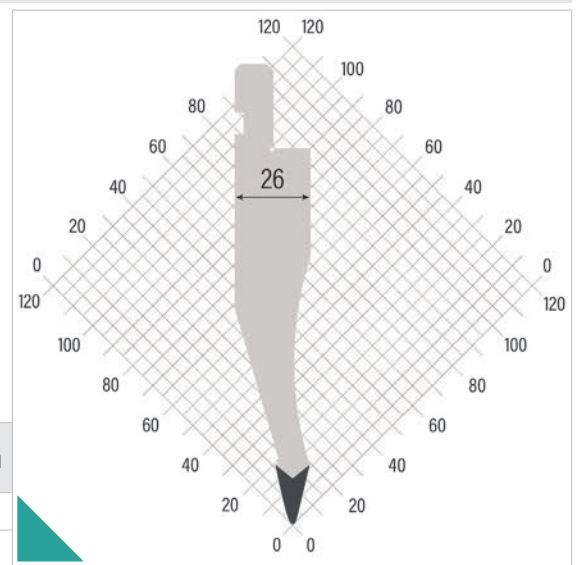

RÉF	$\alpha$	R	H	T/m
POIN10.520	30°	0.50	135.00	50
POIN10.550	30°	0.50	105.00	50

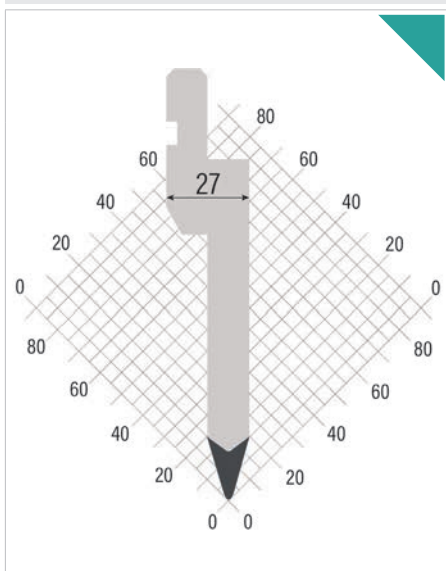

RÉF	$\alpha$	R	H	T/m
POIN10.330	26°	0.80	11700	100

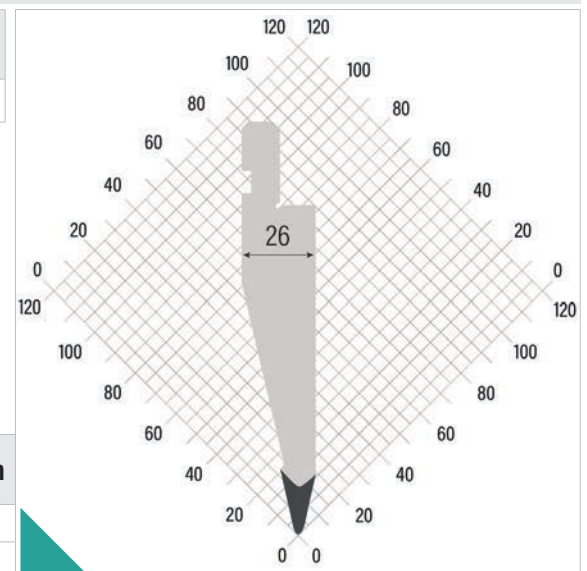

RÉF	$\alpha$	R	H	T/m
POIN11.780	26°	0.80	11700	100
POIN11.920	26°	3.00	11700	100





## Matrices

RÉF	RÉFÉRENCE	T/m	Résistance tonne/mètre
Dimensions exprimées en millimètre			
<b>a</b>	Angle		
Parties des matrices avec traitement de dureté			

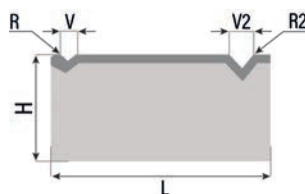

H	Hauteur
L	Largeur de base
V	Largeur du vé
R	Rayon

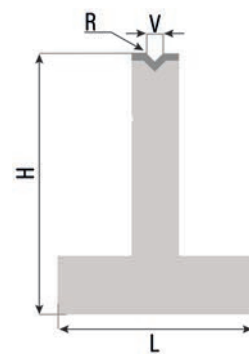
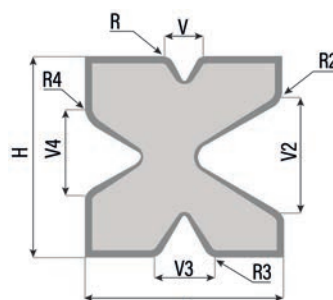
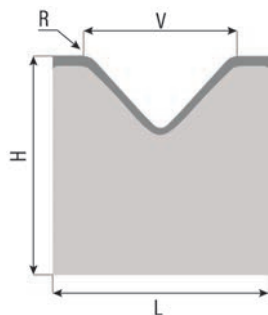
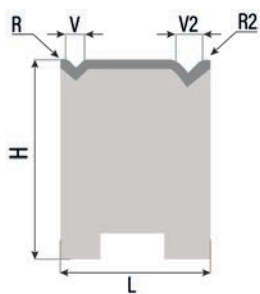

### MATRICE COURTE

Référence + lettre C

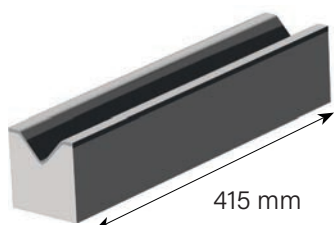

### MATRICE LONGUE

Référence + lettre L

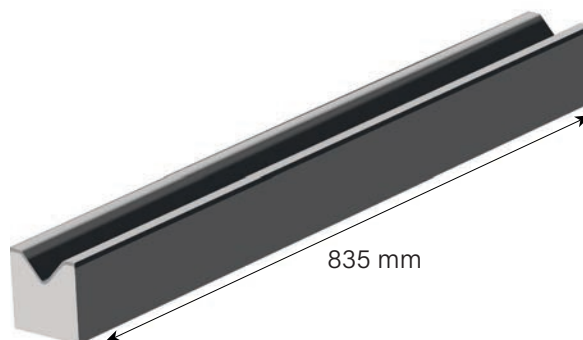

### MATRICE FRACTIONNÉE

Référence + lettre F

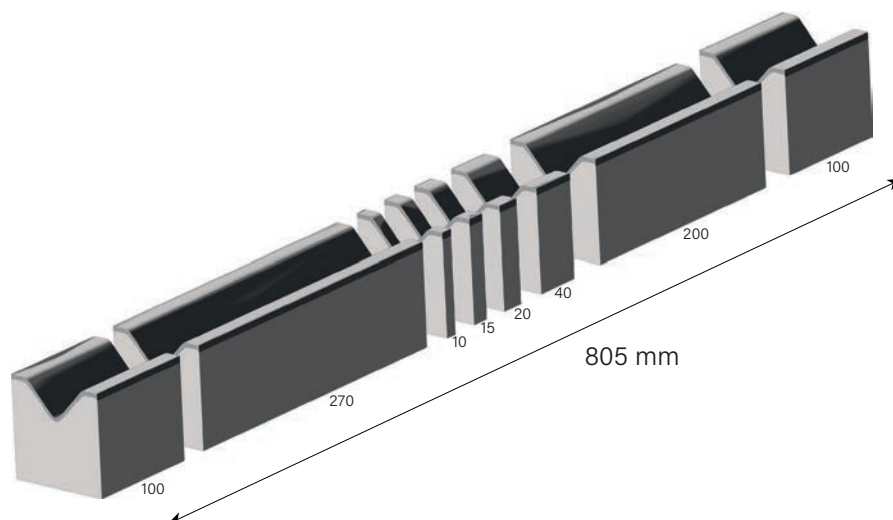

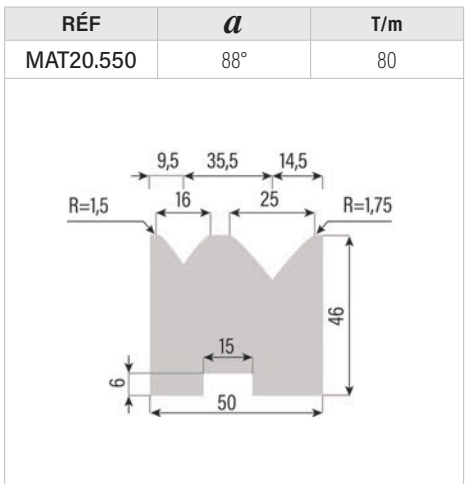
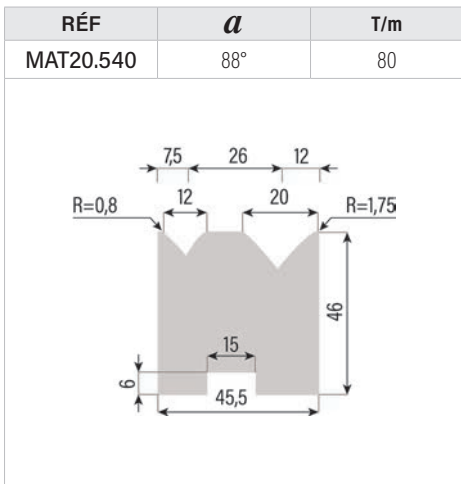
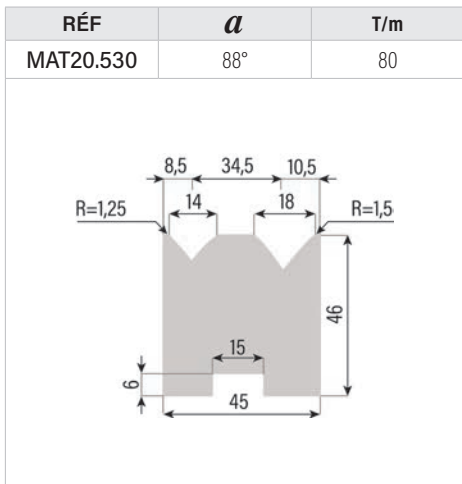
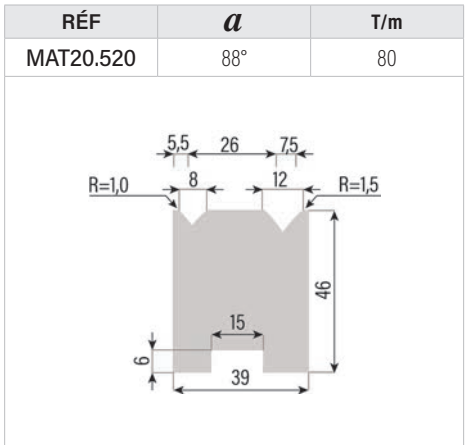
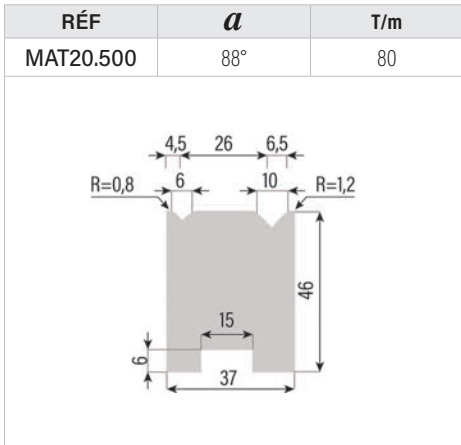
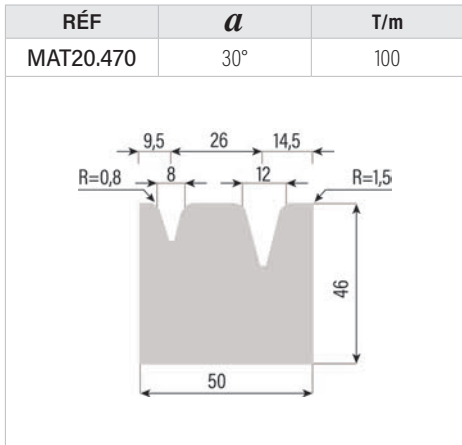
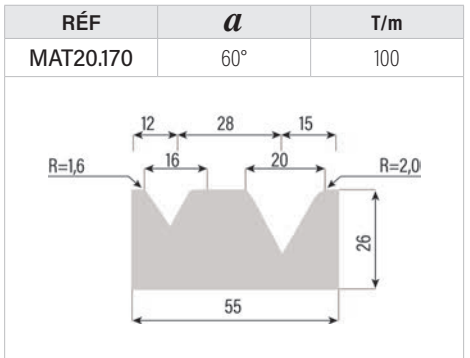
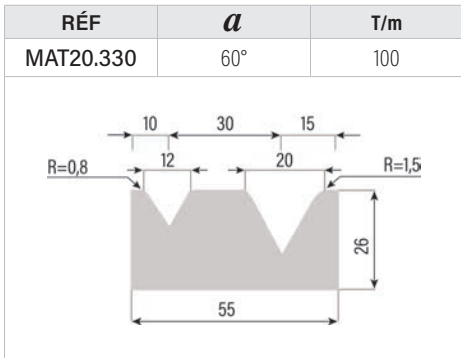
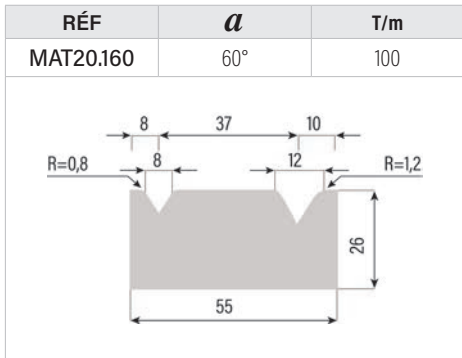
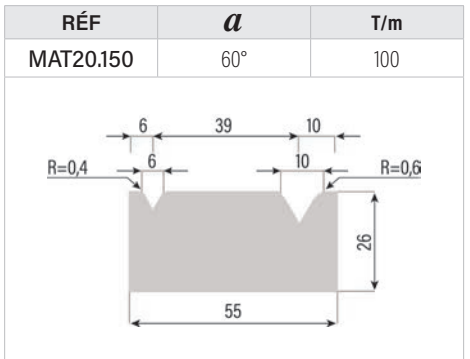
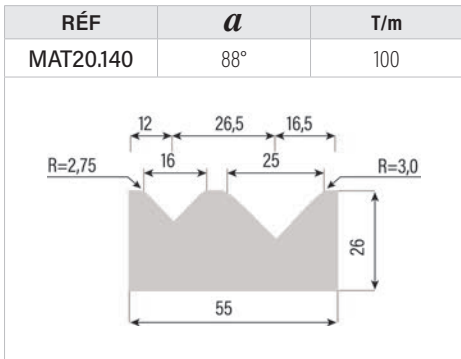
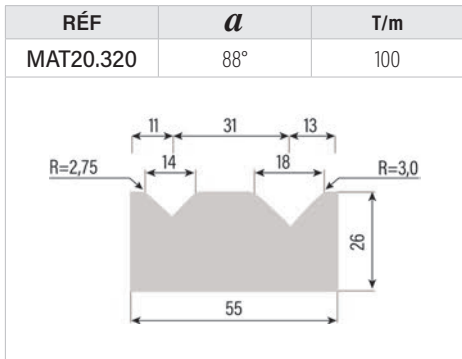
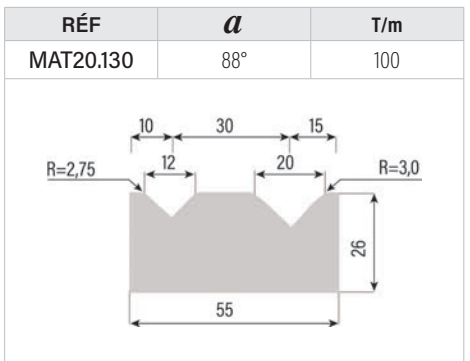
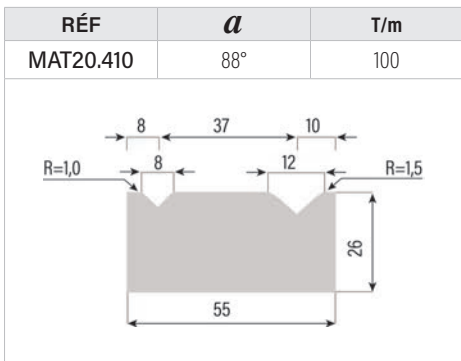
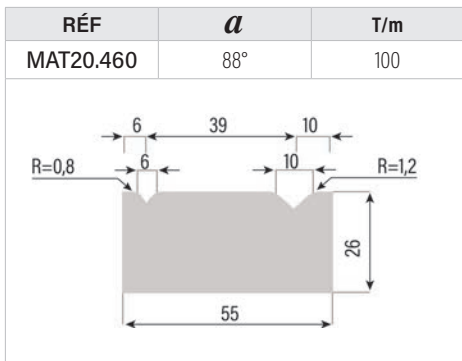



## Matrices

RÉF	$\alpha$	T/m	RÉF	$\alpha$	T/m	RÉF	$\alpha$	T/m
MAT20.560	30°	40	MAT20.570	30°	40	MAT20.580		Support pour matrice de 15mm
MAT20.310		100	MAT20.300	88°   85°	80	MAT20.670	85°	80
MAT20.340	60°	60	MAT20.200	85°	100	MAT20.210	85°	100



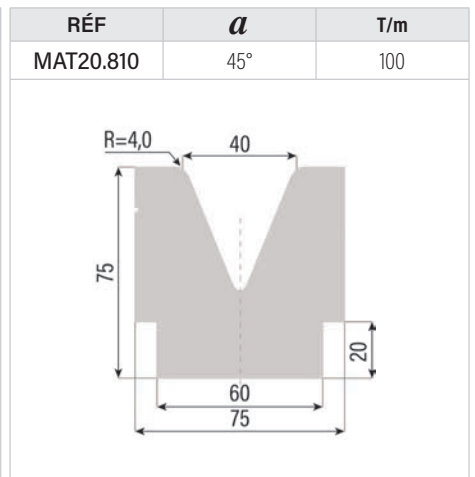
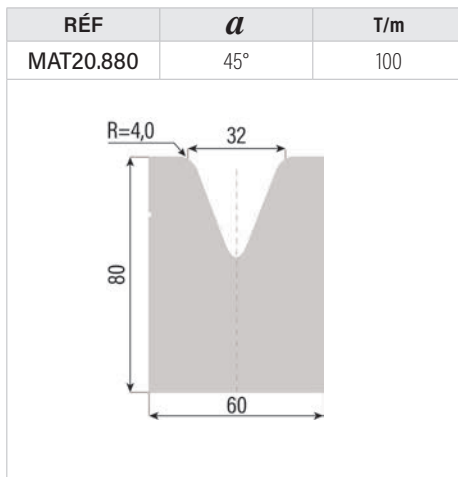
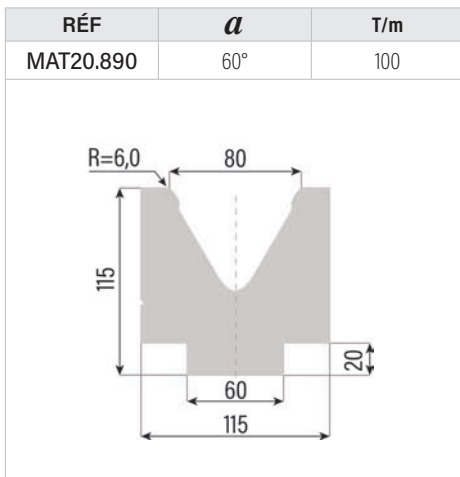
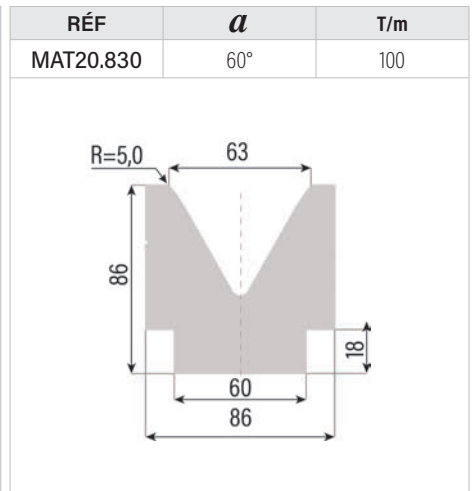
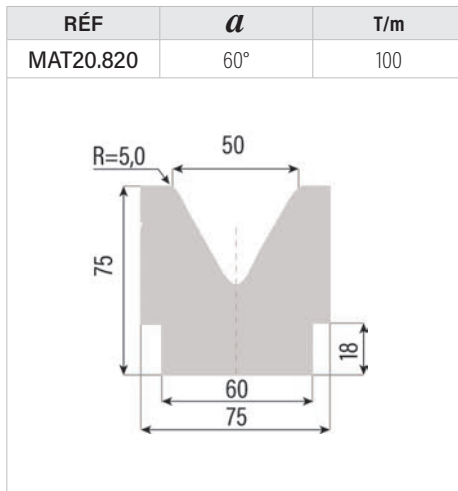
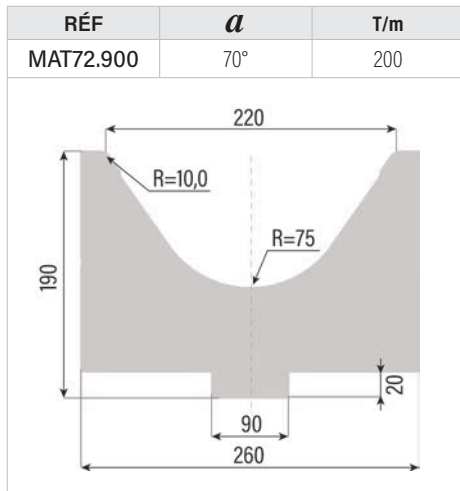
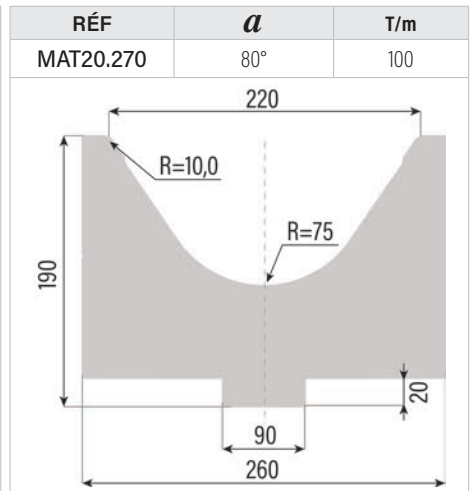
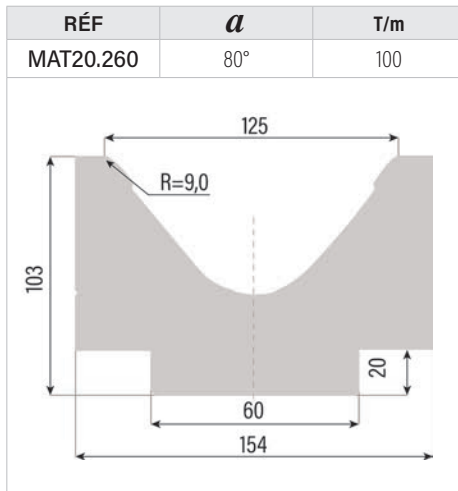
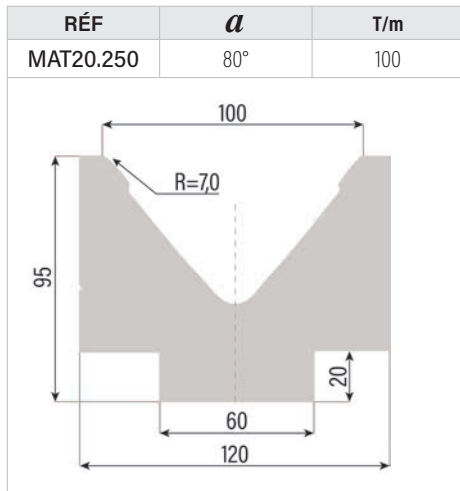
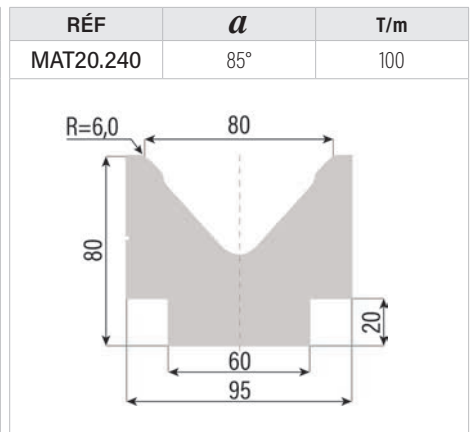
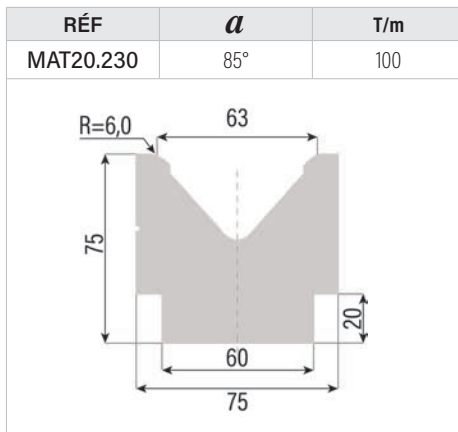
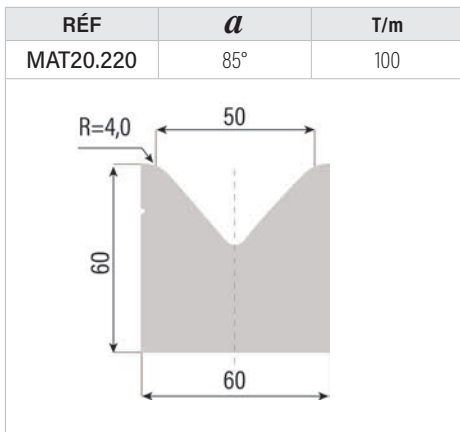



## Matrices

RÉF	$\alpha$	T/m
MAT21.180	45°	100

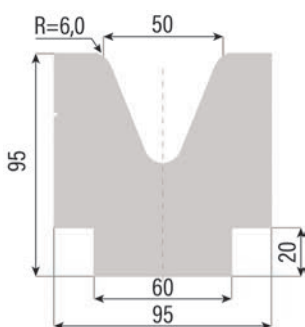

RÉF	$\alpha$	T/m
MAT21.170	45°	100

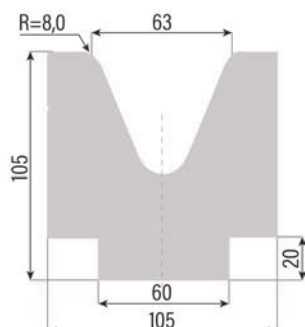

RÉF	$\alpha$	T/m
MAT20.840	45°	100

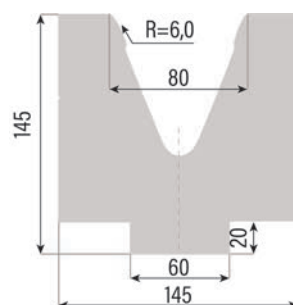

RÉF	$\alpha$	T/m
MAT20.860	30°	100

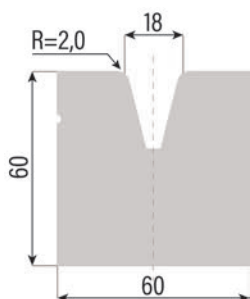

RÉF	$\alpha$	T/m
MAT20.870	30°	100

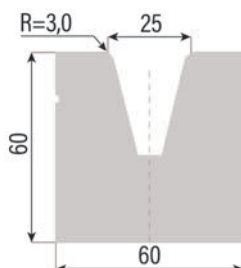

RÉF	$\alpha$	T/m
MAT30.800	88°	100

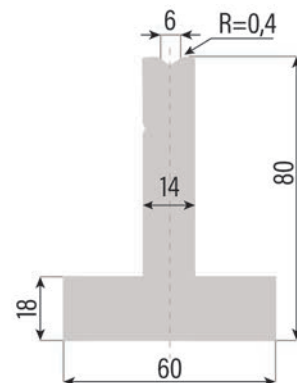

RÉF	$\alpha$	T/m
MAT30.810	88°	100

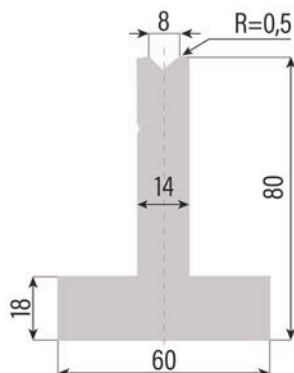

RÉF	$\alpha$	T/m
MAT30.820	88°	100

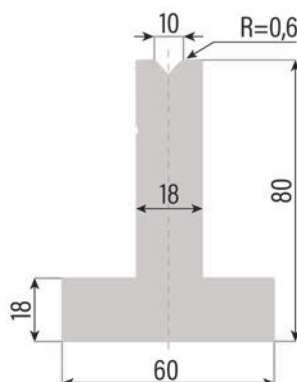

RÉF	$\alpha$	T/m
MAT30.150	88°	100

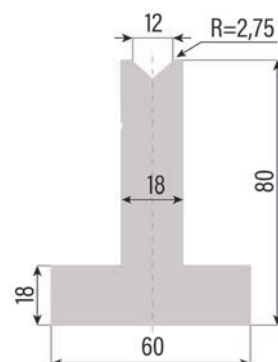

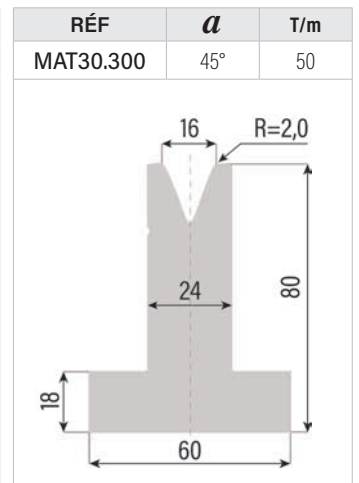
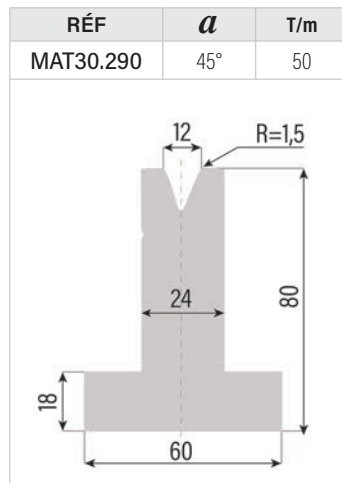
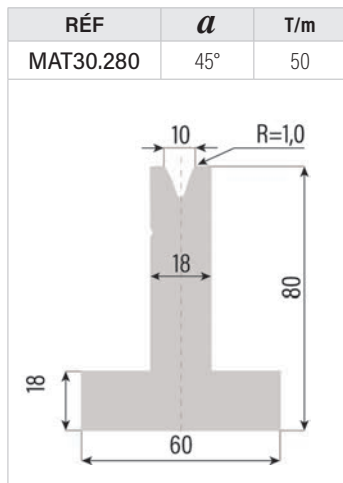
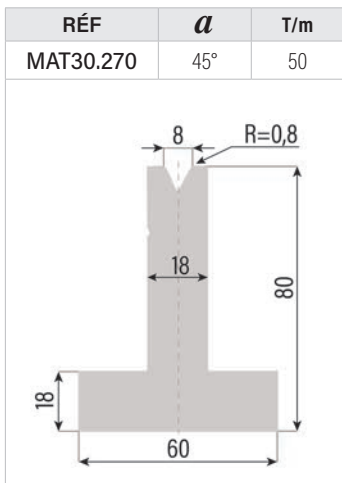
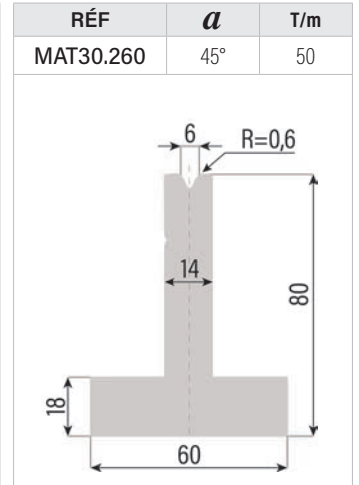
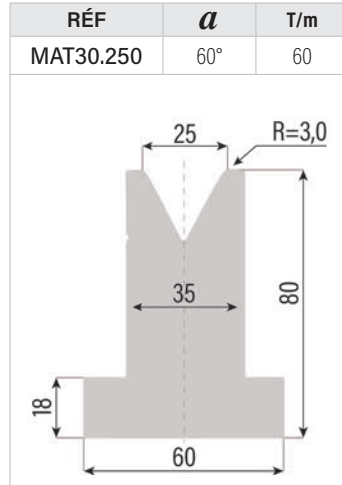
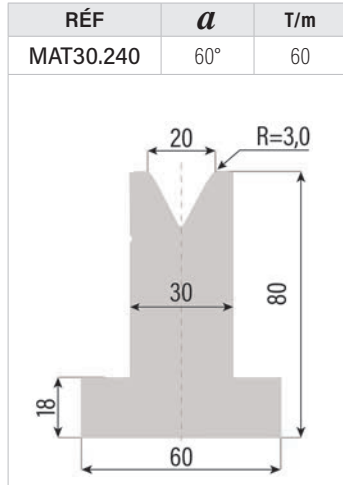
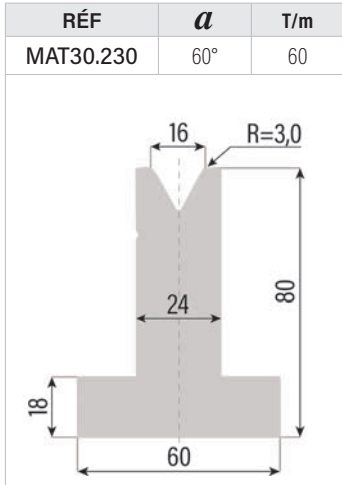
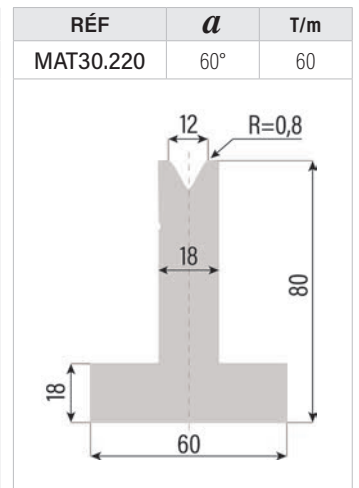
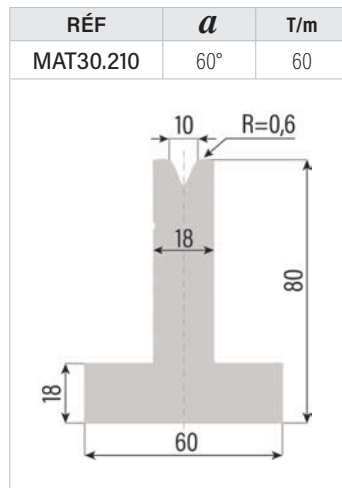
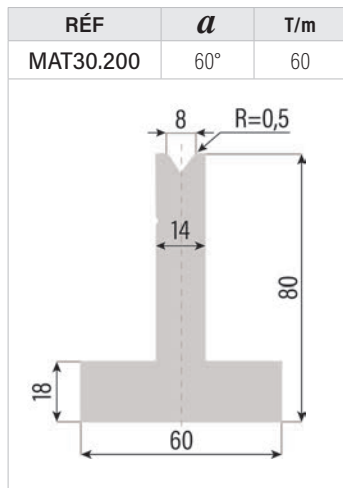
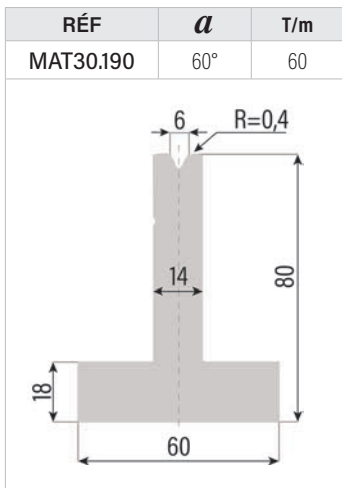
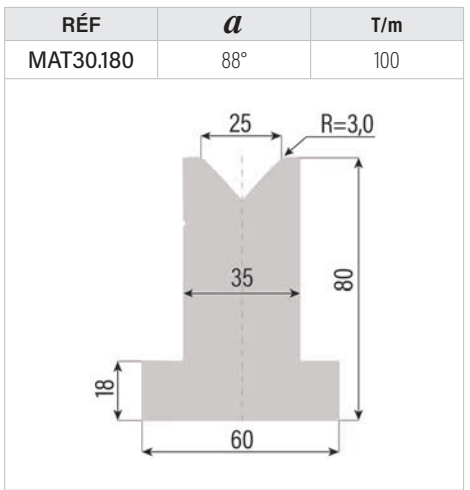
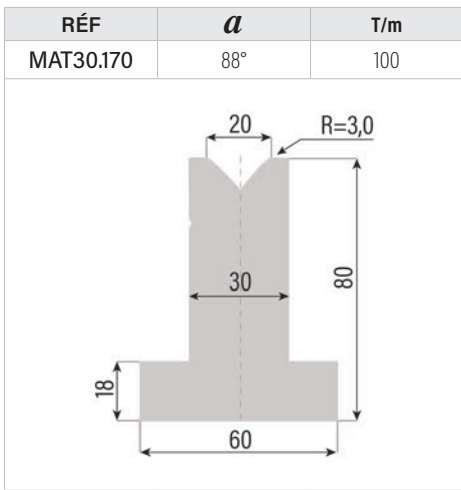
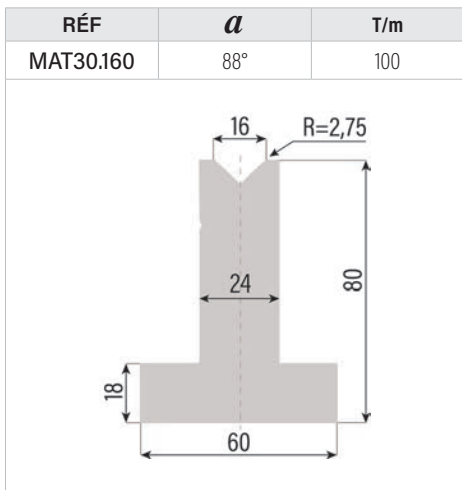





## Matrices

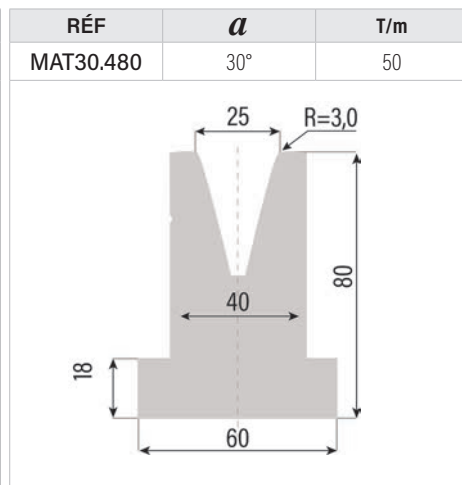
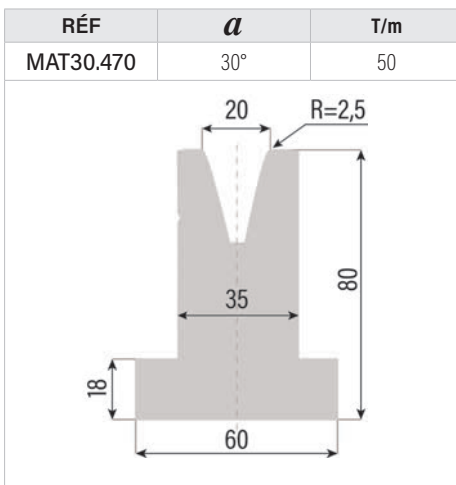
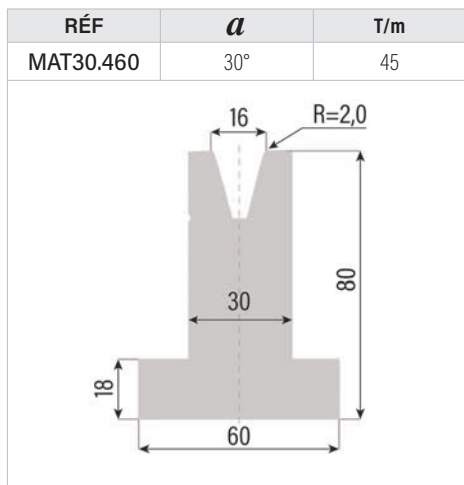
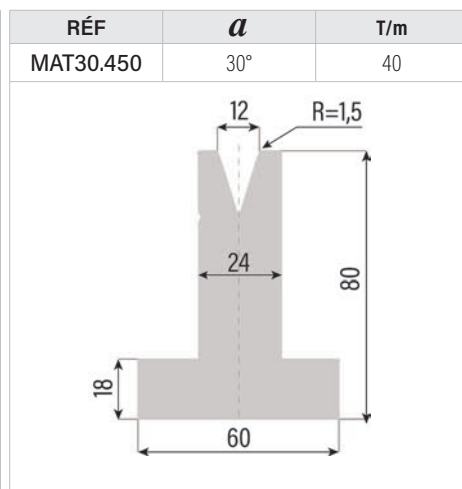
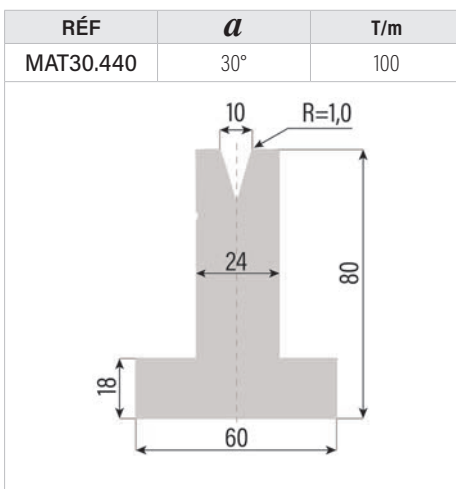
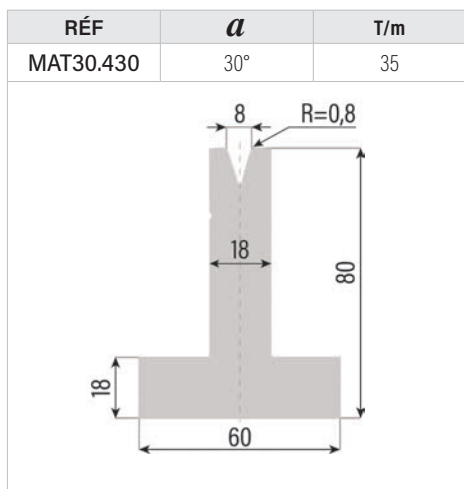
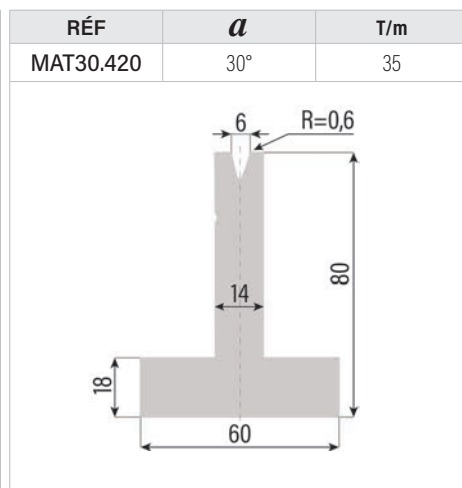
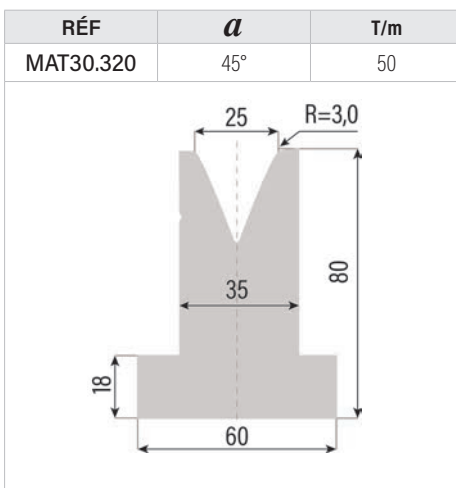
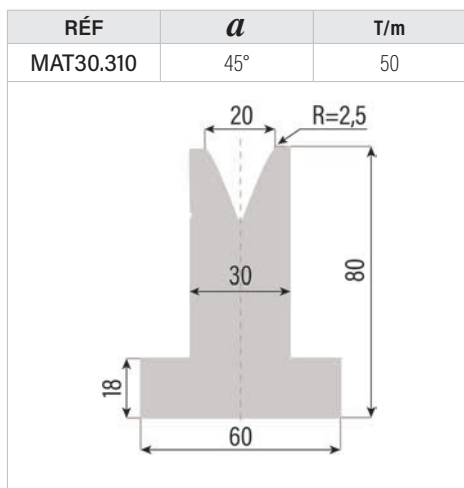

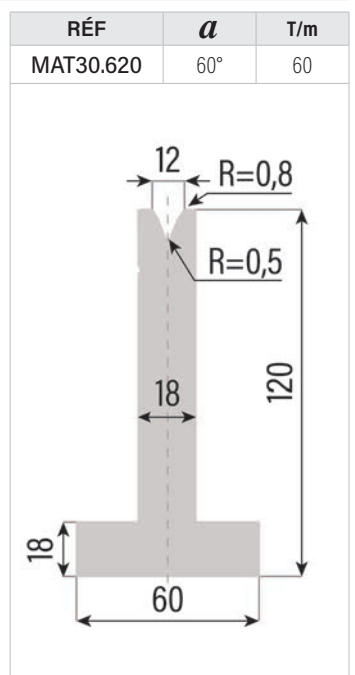
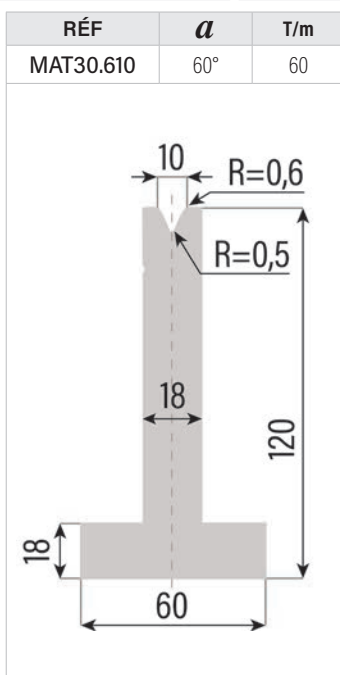
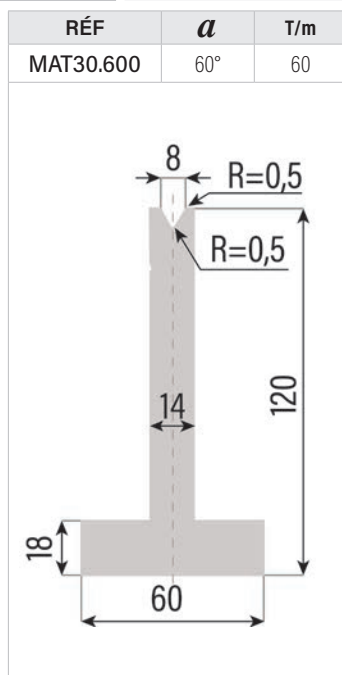
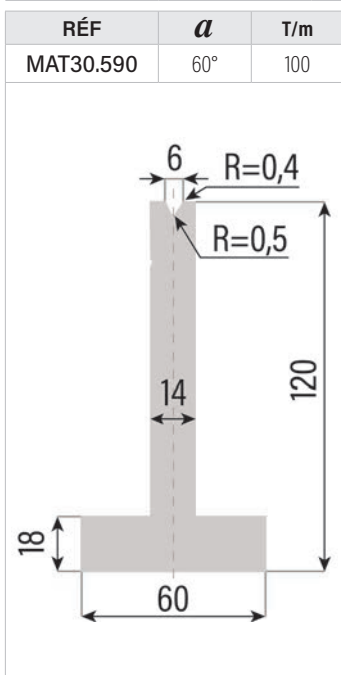
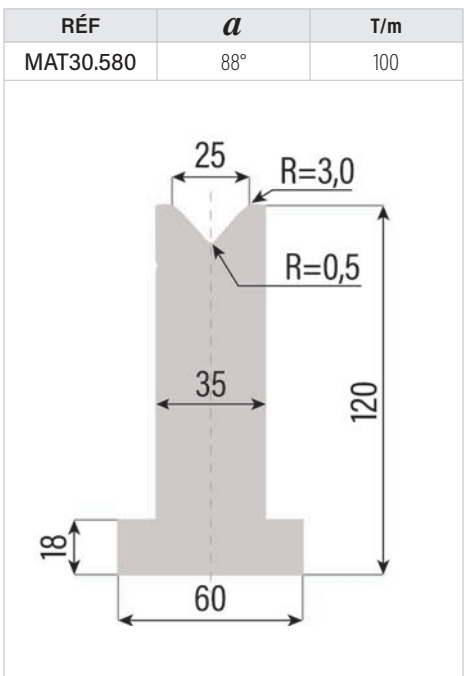
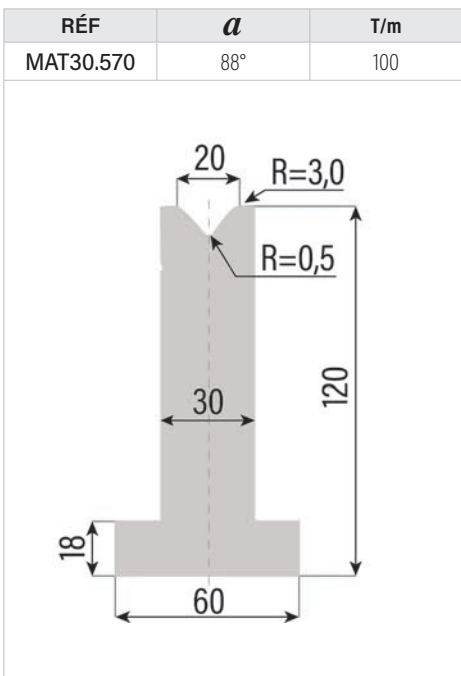
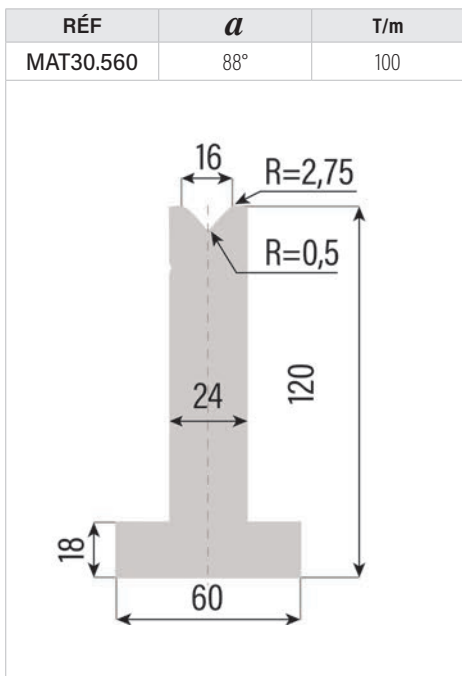
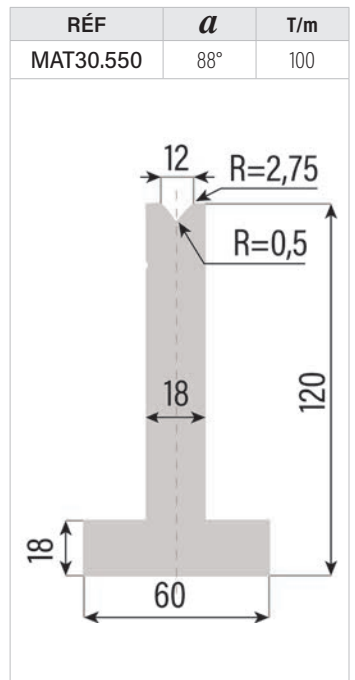
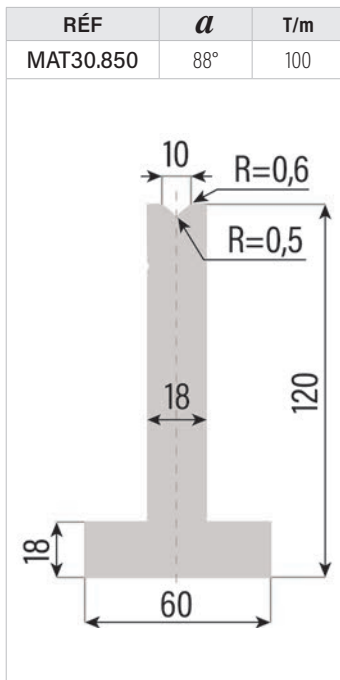
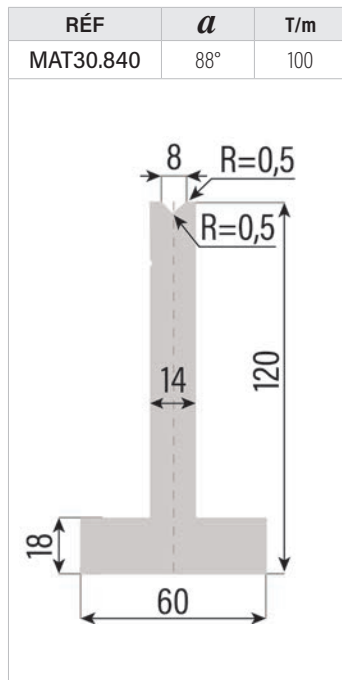
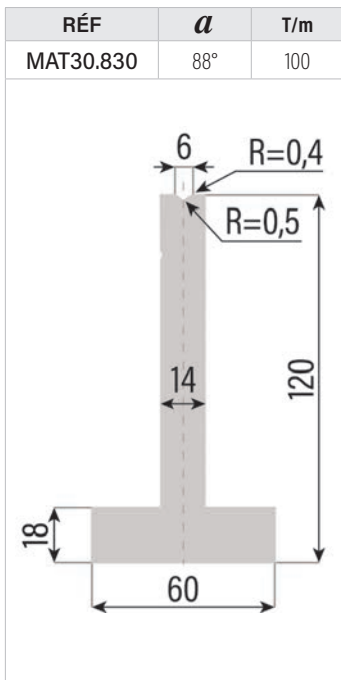



## Matrices

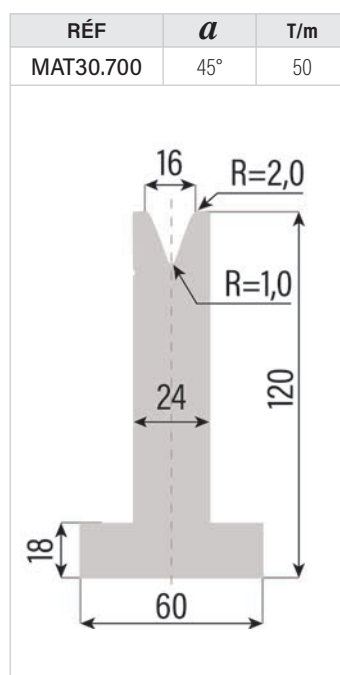
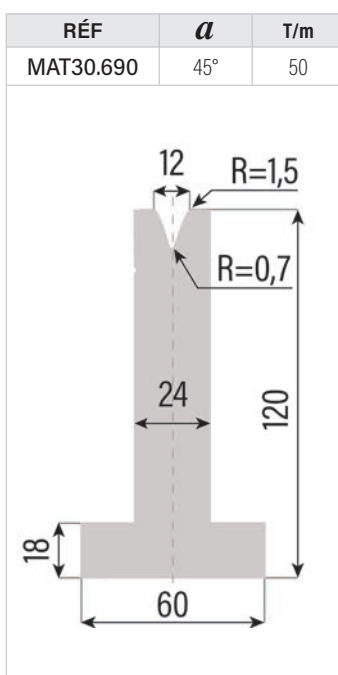
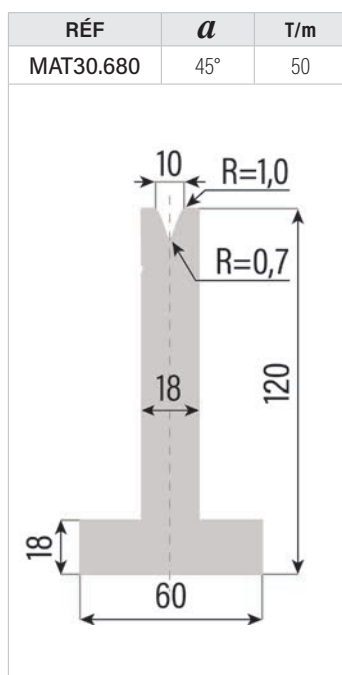
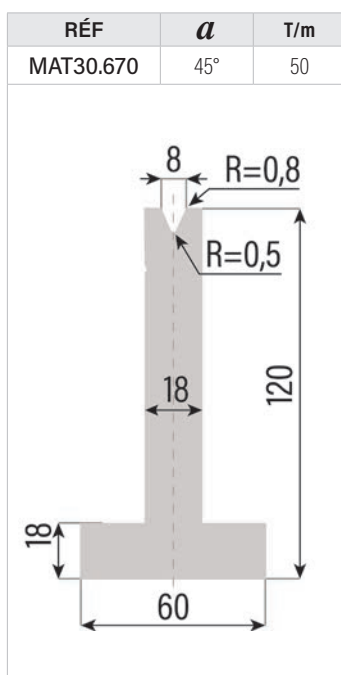
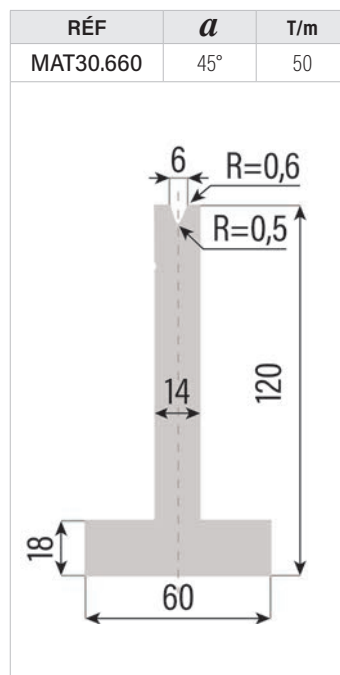
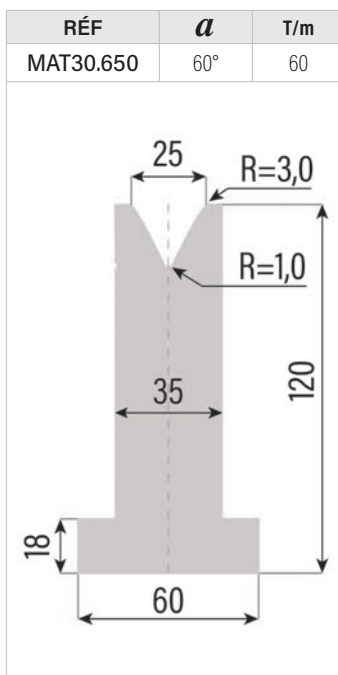
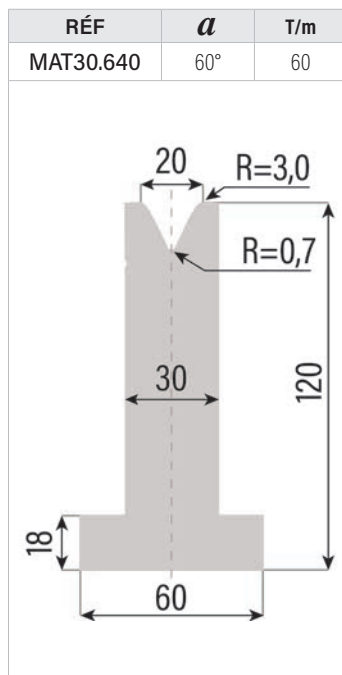
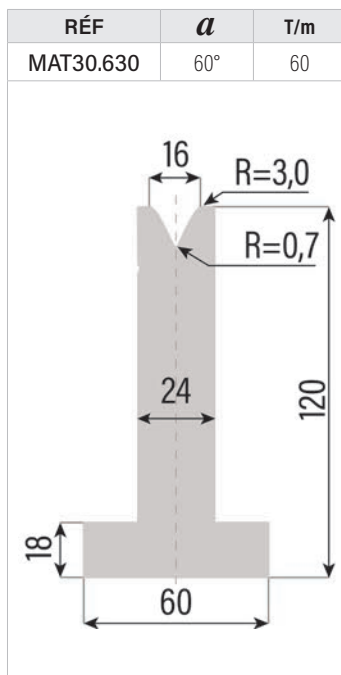

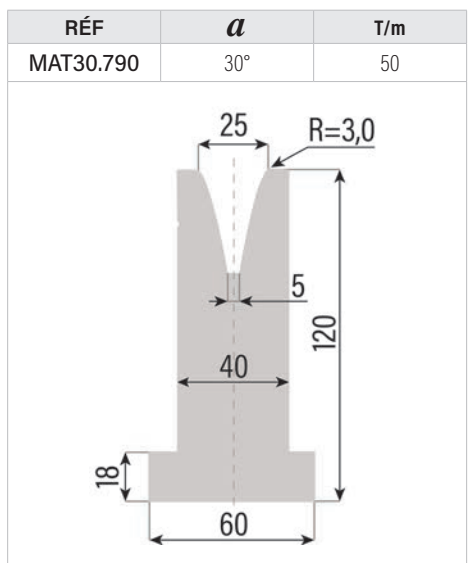
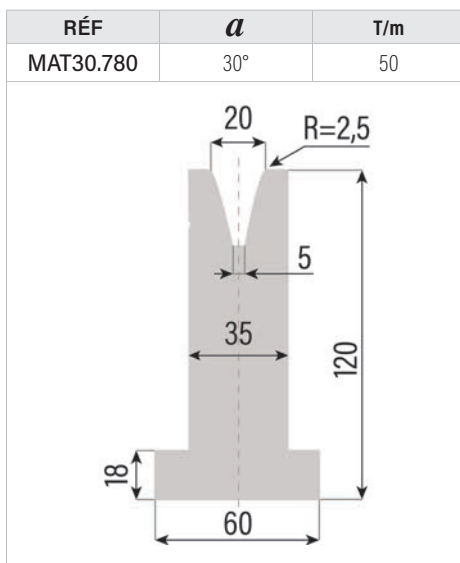
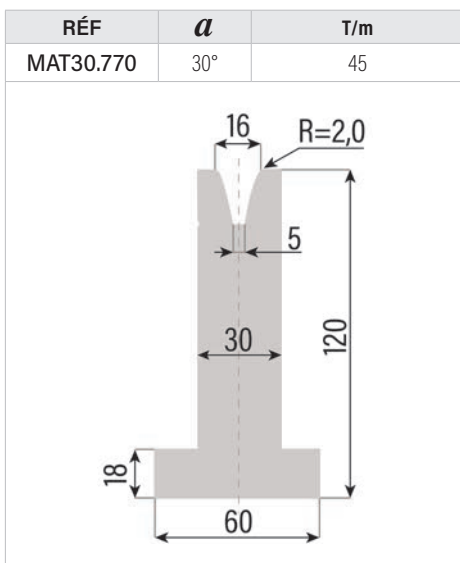
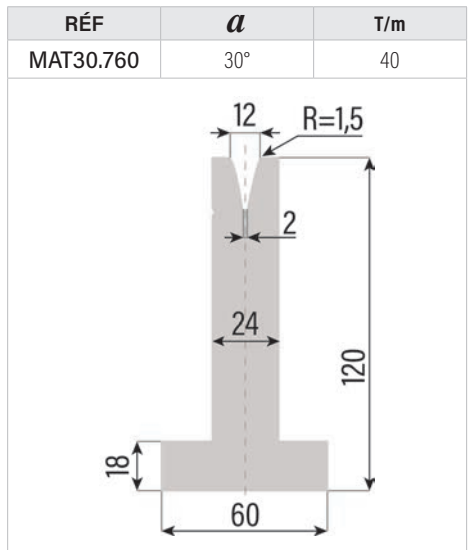
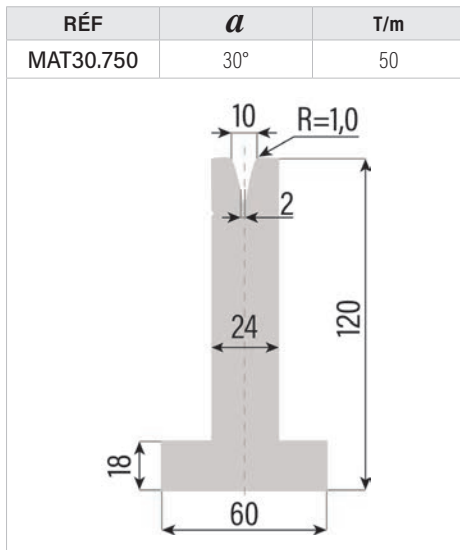
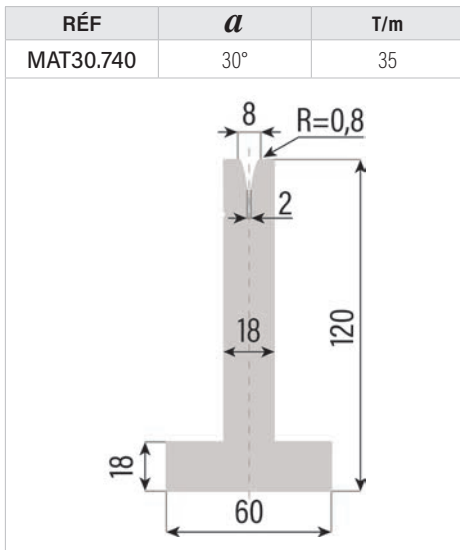
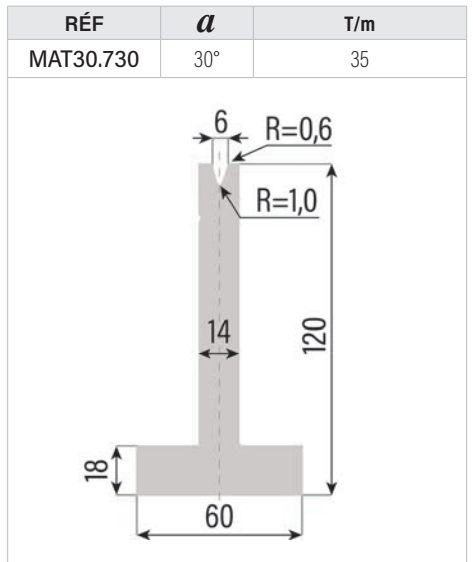
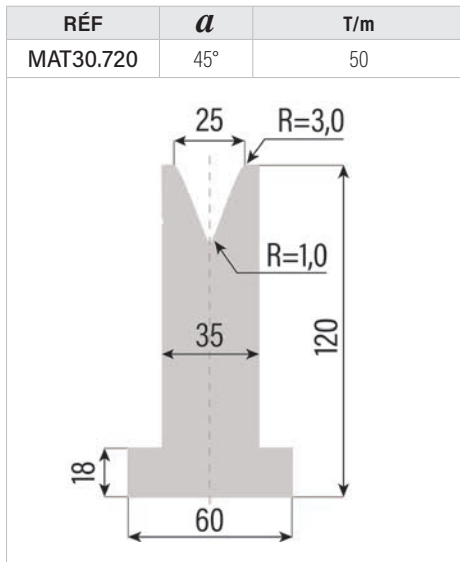
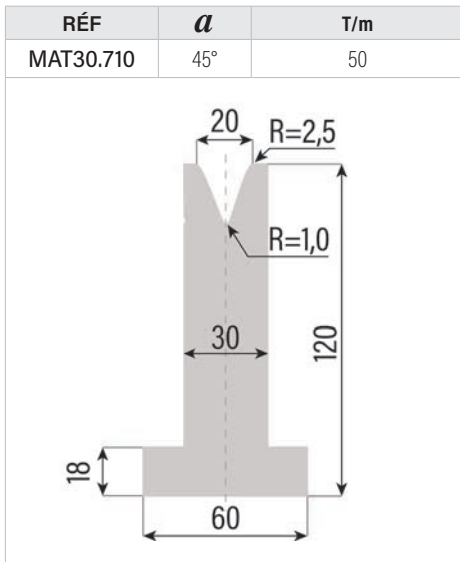





## ■ Outils à écraser

**Dureté 40 daN/mm<sup>2</sup>**

E(mm)	(T/m)	A(mm)	(T/m)	2E(mm)
0,6	9	3	23	1,2
0,8	12	3	32	1,6
1,0	15	3,5	40	2,0
1,25	17	3,5	50	2,5
1,5	22	4,6	63	3,0
2,0	30	5,5	80	4,0
2,5	55	6,5	90	5,0
3,0	70	8,0	100	6,0

**Dureté 70 daN/mm<sup>2</sup>**

E(mm)	(T/m)	A(mm)	(T/m)	2E(mm)
0,6	15	3	35	1,2
0,8	20	3	50	1,6
1,0	25	3,5	60	2,0
1,25	26	3,5	80	2,5
1,5	38	4,6	95	3,0
2,0	50	5,5	100	4,0

RÉF	$\alpha$	T/m
MAT30.400	26°	100

RÉF	$\alpha$	T/m
MAT30.380	26°	100

RÉF	$\alpha$	T/m
MAT30.410	30°	80

RÉF	$\alpha$	T/m
MAT30.390	35°	80

RÉF	$\alpha$	T/m
MAT30.370/6	35°	60

RÉF	$\alpha$	T/m
MAT30.370/8	35°	60

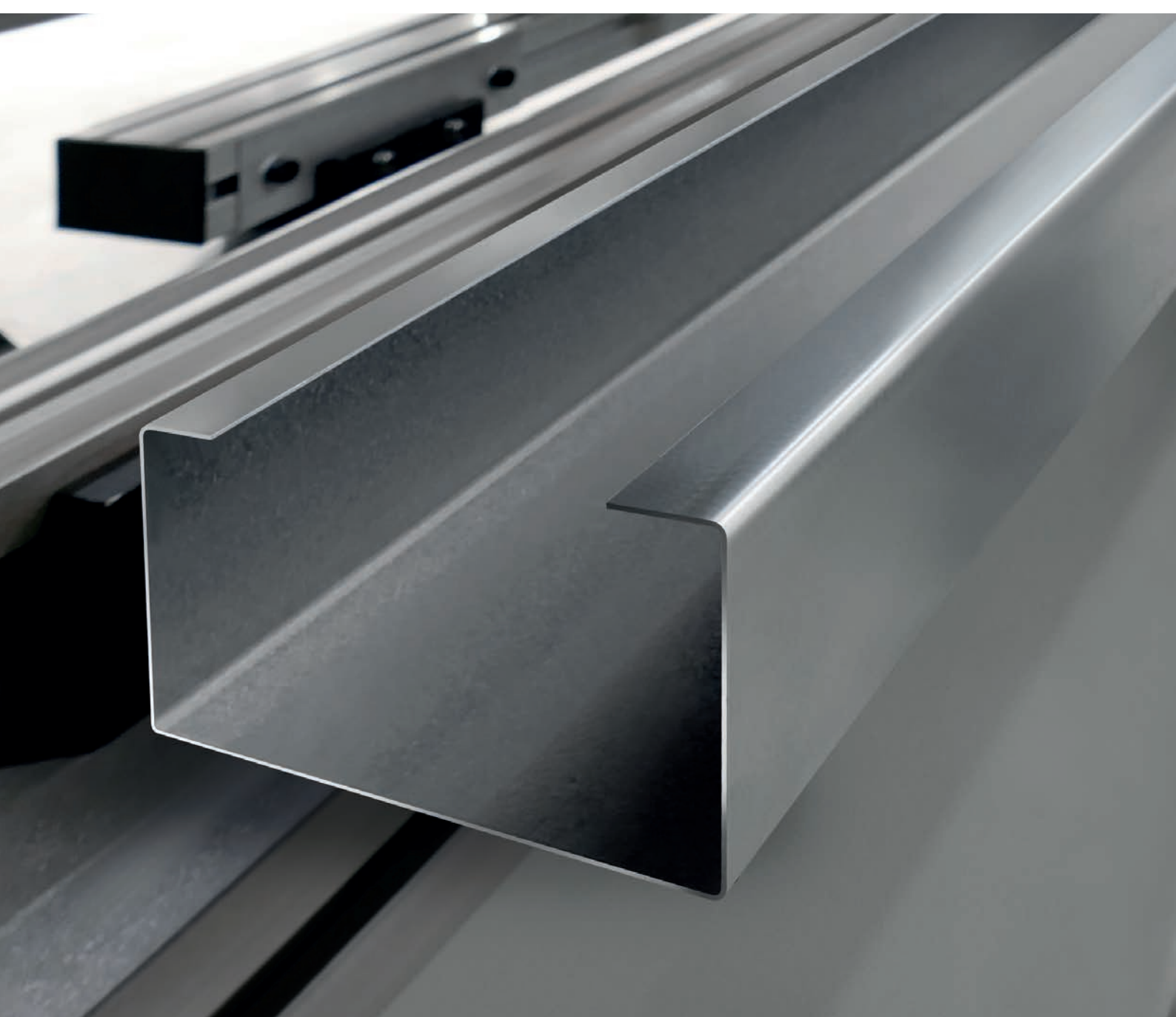



## Une équipe commerciale & technique à votre service !

### OUEST

Guillaume CABIOU  
Mobile : +33 6 73 41 12 75  
e-mail : com-ouest@jouanel.com

### CENTRE

Maxime PUY  
Mobile : +33 6 98 41 12 75  
e-mail : com-centre@jouanel.com

### SUD-OUEST

Jérôme LECOQ  
Mobile : +33 6 80 41 12 75  
e-mail : com-sudouest@jouanel.com

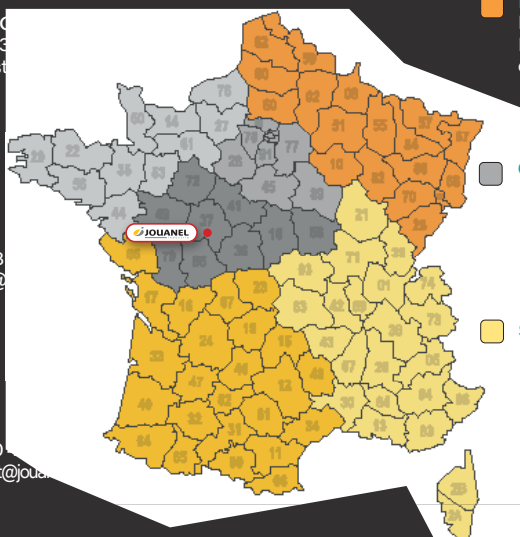

### NORD-EST

Benoît PIERARD  
Mobile : +33 6 75 69 70 85  
e-mail : com-nordest@jouanel.com

### Grand IDF

Arnaud MELEUX  
Mobile : +33 6 07 53 49 40  
e-mail : com-idfcentre@jouanel.com

### SUD-EST

Alain BOUCHET  
Mobile : +33 6 85 41 12 79  
e-mail : a.bouchet@jouanel.com

### Directeur Commercial

Guylaine JUSTE  
Tél. : +33 2 47 65 45 61  
Mobile : +33 6 85 41 21 75  
e-mail : g.juste@jouanel.com

### Export

#### Commercial Export

Kamil JURGIELEWICZ  
Tél. : +33 247 349 344  
Mobile : +48 668 471 327  
e-mail : k.jurgielewicz@jouanel.com

#### Commercial Export - Espagne / Benelux

Arnaud MELEUX  
Tél. : +33 608 489 850  
e-mail : com-export@jouanel.com

#### Commercial Export Suisse / Ile de la Réunion

Alain BOUCHET  
Mobile : +33 685 411 279  
e-mail : a.bouchet@jouanel.com

#### Assistant Export

Pierre RABOIN  
Tél. : +33 247 651 651  
e-mail : export@jouanel.com

### Service d'Assistance Technique

Tél. : +33 2 47 65 16 49  
e-mail : contactsat@jouanel.com

### Offres Commerciales France

Secteurs Nord-Est - Centre - Ouest - Sud-Ouest  
Elodie DAGUET  
Tél. : +33 2 47 34 93 42  
e-mail : contact@jouanel.com

Secteurs Grand-IDF - Sud-Est  
Anaïs CHARTIER  
Tél. : +33 2 47 65 16 52  
e-mail : com-st@jouanel.com

### Commandes & Suivi Transport France

Christiane SOREL  
Tél. : +33 2 47 65 47 18  
e-mail : c.sorel@jouanel.com

www.jouanel.com



Édition  
01/2023

## Nous contacter

### Siège social & usine

JOUANEL Industrie • 30 rue des Saulniers  
37800 Sainte-Maure-de-Touraine • FRANCE

Tél. : +33 2 47 65 40 67 • Fax : +33 2 47 65 51 61  
e-mail : info@jouanel.com

TVA Intracommunautaire : FR15331327072

Suivez-nous  
sur notre chaîne



www.jouanel.com

Votre distributeur :

